

# **IS4920 / IS4921**

---

Area Imaging Decode Engine

## **Integration Guide**

---

## Disclaimer

Honeywell International Inc. (“HII”) reserves the right to make changes in specifications and other information contained in this document without prior notice, and the reader should in all cases consult HII to determine whether any such changes have been made. The information in this publication does not represent a commitment on the part of HII.

HII shall not be liable for technical or editorial errors or omissions contained herein: nor for incidental or consequential damages resulting from the furnishing, performance, or use of this manual.

This document contains propriety information that is protected by copyright. All rights reserved. No part of this document may be photocopied, reproduced, or translated into another language without the prior written consent of HII.

© 2007 - 2010 Honeywell International Inc. All rights reserved.

Web Address: [www.honeywellaidc.com](http://www.honeywellaidc.com)

## Trademarks

Metrologic, MetroSelect, MetroSet2, MetroVision, Omniplanar, and FirstFlash are trademarks or registered trademarks of Metrologic Instruments, Inc. or Honeywell International Inc.

Microsoft, Windows, and Windows 95 are trademarks or registered trademarks of Microsoft Corporation.

Molex, *FFC/FPC*, and SlimStack are trademarks or registered trademarks of Molex, Inc.

Other product names mentioned in this manual may be trademarks or registered trademarks of their respective companies and are the property of their respective owners.

---

# Table of Contents

## **Introduction**

Product Overview .....	1
Models and Accessories .....	2
Components of the IS4920 / IS4921 Decode Engine	
IS4920-0 / IS4921-0 (Bracket Not Included) .....	3
IS4920-1 / IS4921-1 (Bracket Included) .....	3
Components of the IS4910 / IS4911 (Non-Decode Engine).....	4
Components of the Decode Printed Circuit Board	
TTL Level RS232 .....	5
USB.....	5
Labels .....	5

## **Mounting Specifications**

IS4910-00 / IS4911-00 Non-Decode Engine Dimensions .....	6
IS4910-01 / IS4911-01 Non-Decode Engine Dimensions .....	7
IS4910-02 / IS4911-02 Non-Decode Engine Dimensions .....	8
Decode Printed Circuit Board Dimensions	
TTL Level RS232 .....	10
USB.....	10
IS4920-2 / IS4921-2 Bracketed Decode Engine Dimensions.....	11
Enclosure Specifications	
Electrostatic Discharge (ESD) Cautions .....	12
Airborne Contaminants and Foreign Materials.....	12
Output Window Properties .....	13
Output Window Coatings .....	13
Optical Clearance Specifications .....	14

## **System Considerations**

Power Supply .....	15
Host Flex Cable.....	15
Power Sequencing .....	15
Thermal Considerations .....	15

---

<b><i>Theory of Operation</i></b>	
Overview .....	16
Host Interface Signals .....	17
Usage of Host Interface Signals .....	18
Power Mode Descriptions .....	20
<b><i>Serial Configurations</i></b> .....	<b>26</b>
Abbreviated ASCII Table .....	27
<b><i>Operational Timing</i></b>	
Power Up/Boot Up.....	28
Power Down/Suspend/Power Removed .....	30
Decode Timing .....	31
Summary of Operation Timings.....	32
<b><i>Depth of Field vs Bar Code Element</i></b>	
IS4910 .....	33
IS4911 .....	34
<b><i>Exposure Time for Image Acquisition</i></b> .....	<b>35</b>
<b><i>Design Specifications</i></b>	
Operational .....	36
Mechanical .....	37
Environmental .....	37
Electrical .....	38
Detailed Electrical Specifications .....	38
Current Waveforms .....	40
<b><i>Imaging Engine and Decode PCB Terminations</i></b>	
Imaging Engine Interface Connector.....	42
Decode Board (USB & TTL) Interface Connector .....	43
Decode Board (USB) Output to Host Connector .....	44
Decode Board (TTL) Output to Host Connector .....	45
<b><i>Flex Cable Specifications</i></b>	
Flex Cable Pinout – Imaging Engine Connection .....	46
Flex Cable Pinout – Decode Board Connection .....	47
Dimensions.....	48
Installation Notes .....	49

---

**Regulatory Compliance**

Safety .....50

    Europe.....50

    United States.....51

    Canada.....51

**Limited Warranty .....52**

**Patents.....53**

**Index .....54**

**Customer Support .....56**

    Technical Assistance.....56

    Product Service and Repair .....57



## **Product Overview**

The IS4920 is a miniature area-imaging engine and decode board with image capturing and bar code decoding capabilities. The engine module consists of a non-decode imaging engine (IS4910), a decode board and two flex cables. The IS4920 features a mega-pixel CMOS sensor, integrated illumination, and patented FirstFlash® technology; together they ensure capturing a high-resolution image with optimal brightness each time. IS4920 also has a wide-angle lens design, which covers a large scan area and delivers a true omni-directional scanning performance. The high-quality images produced by the imaging engine can be used for decoding bar codes, image upload, signature capture, document lifting and reading OCR fonts.

The decode board is powered by a fast processor and SwiftDecoder™ software to decode a wide array of 1D and 2D bar codes plus OCR fonts. The decode board supports TTL level RS232 or USB 1.1 communication. The decode board is compatible with MetroSet2, a PC-based software for easy configuration.

IS4920 is designed with the industrial standard size, mounting options and output to facilitate integration into existing applications. The imaging engine's miniature size makes IS4920 ideal for integration into data terminals and other small devices. IS4920 is supplied as an assembled module with a mounting bracket or as separate components for custom mounting. The imaging engine's unique open system architecture allows IS4920 to accept third party and custom plug-ins, giving the IS4920 virtually unlimited application flexibility. The small yet powerful engine delivers a scanning performance that rivals a full-fledged handheld scanner.

A high-density version, IS4921, is also available.

## Models and Accessories

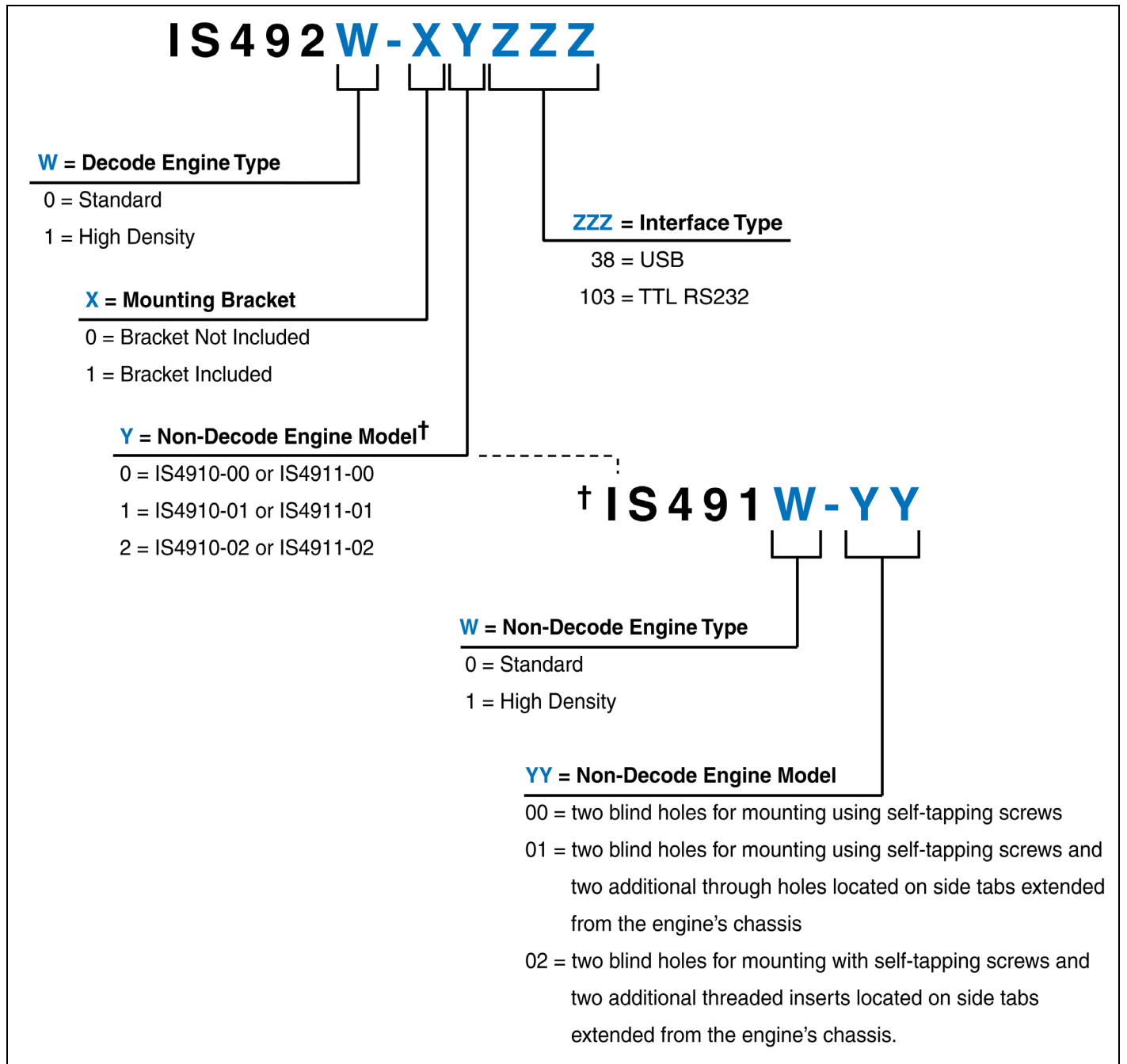


Figure 1. Part Number Designations



## Components of the IS4920 / IS4921 Decode Engine

### IS4920-0 / IS4921-0 (Bracket Not Included)

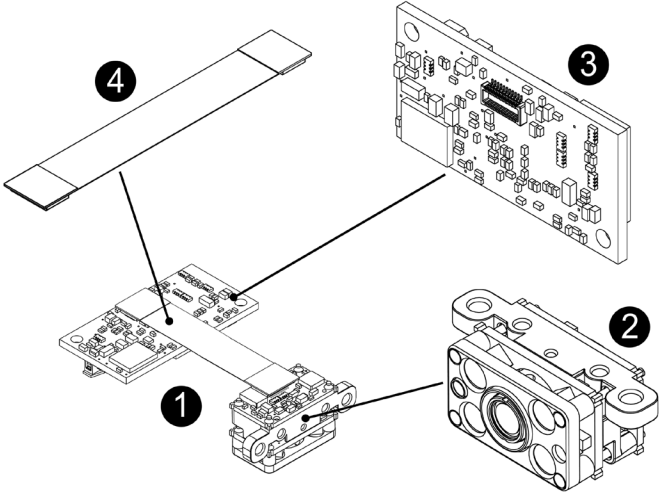
Item No.	Description	Item Location
1	IS4920-0 / IS4921-0 Assembled Decode Engine	
2	IS4910 / IS4911 Non-Decode Engine* See pages 2, 4 and 6 for model specifications.	
3	Decode Board* USB (See page 10) TTL Level RS232 (See page 10)	
4	Flex Cable P/N 77-77101	

Figure 2. IS4920-0 / IS4921-0 \*

### IS4920-1 / IS4921-1 (Bracket Included)

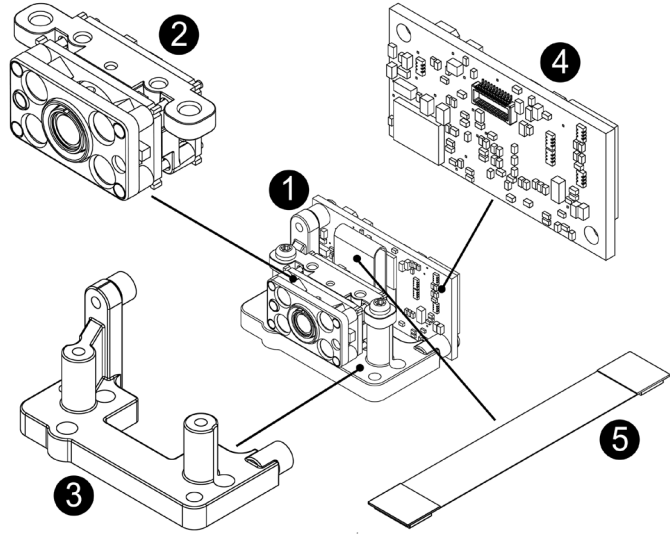
Item No.	Description	Item Location
1	IS4920-1 / IS4921-1 Assembled Decode Engine	
2	IS4910 / IS4911 Non-Decode Engine* See pages 2, 4 and 6 for model specifications.	
3	Bracket	
4	Decode Board* USB (See page 10) TTL Level RS232 (See page 10)	
5	Flex Cable P/N 77-77101	

Figure 3. IS4920-1 / IS4921-1 \*

\* Figures show the IS4910-01 Non-Decode Engine with a USB Decode PCB.

## Components of the IS4910 / IS4911 Non-Decode Engine

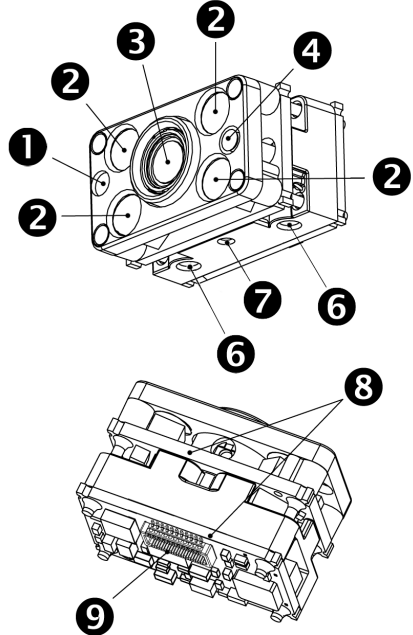
Item No.	Description	Item Location
1	Targeting	
2	Area Illumination	
3	Camera Imager	
4	FirstFlash Aperture	
5	Mounting Points (see pages 7 - 8)	
6	Mounting Points Provided for Self-Tapping Screw (see pages 6 - 8)	
7	Keying Location (see pages 6 - 8)	
8	Printed Circuit Boards	
9	22-Pin, 0.50 mm (0.020") Pitch SlimStack™ Plug, Molex (P/N 55560-0227)	

Figure 4. IS4910-00 / IS4911-00

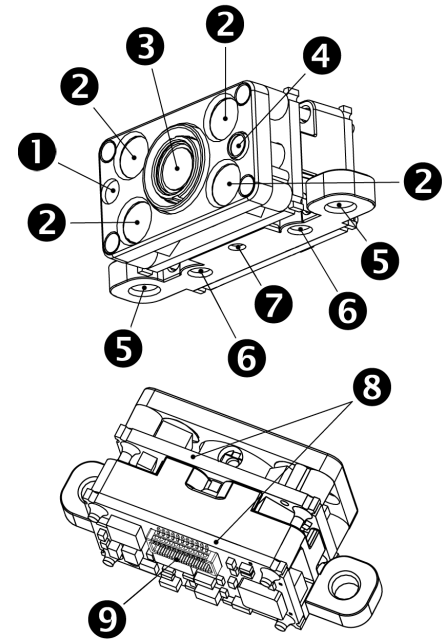


Figure 5. IS4910-01 / IS4910-02  
IS4911-01 / IS4911-02

Molex and SlimStack are trademarks or registered trademarks of Molex, Inc.

## Components of the Decode Printed Circuit Board

### TTL Level RS232

See page 10 for printed circuit board dimensions and connector information.

See page 43 and page 45 for connector pinout information.

### USB

See page 10 for printed circuit board dimensions and connector information.

See page 43 and page 44 for connector pinout information.

### Labels

The serial number/model number label is located on the side of the engine.

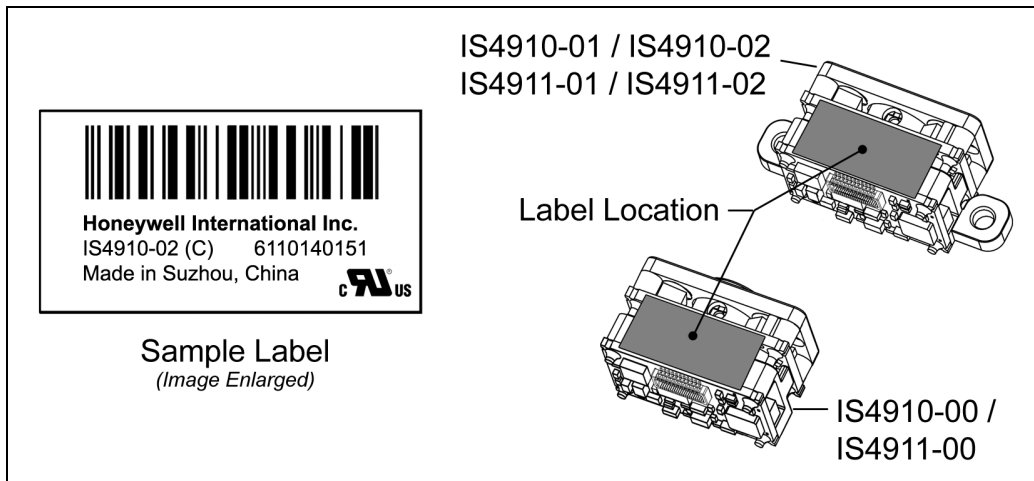


Figure 6. Serial Number Label Sample

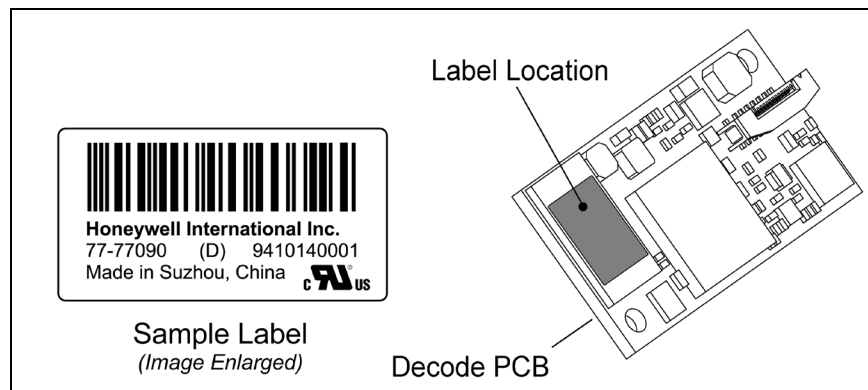


Figure 7. Decode Board (USB Version Shown) Serial Number Label Sample

# Mounting Specifications

## IS4910-00 and IS4911-00 Non-Decode Engine Dimensions

The -00 models include two  $\text{Ø } .075''$  [1.9 mm] blind holes for mounting the engine with self-tapping screws. The mounting holes are located on the bottom of the unit with an additional keying location point for engine alignment.

**Warning:** The limited warranty (on page 52) is void if the following guidelines are not adhered to when mounting the engine.

When securing the engine with screws:

- Use M2.2 x 4.5 Philips pan head, type AB, steel, zinc clear, Trivalent self-tapping screws.
- Do not exceed 1.75 +0.5 in-lb [2.02 +6 cm-kg] of torque during screw installation.
- Use a minimum mount thickness of 0.3 mm.
- Use safe ESD practices when handling and mounting the engine.

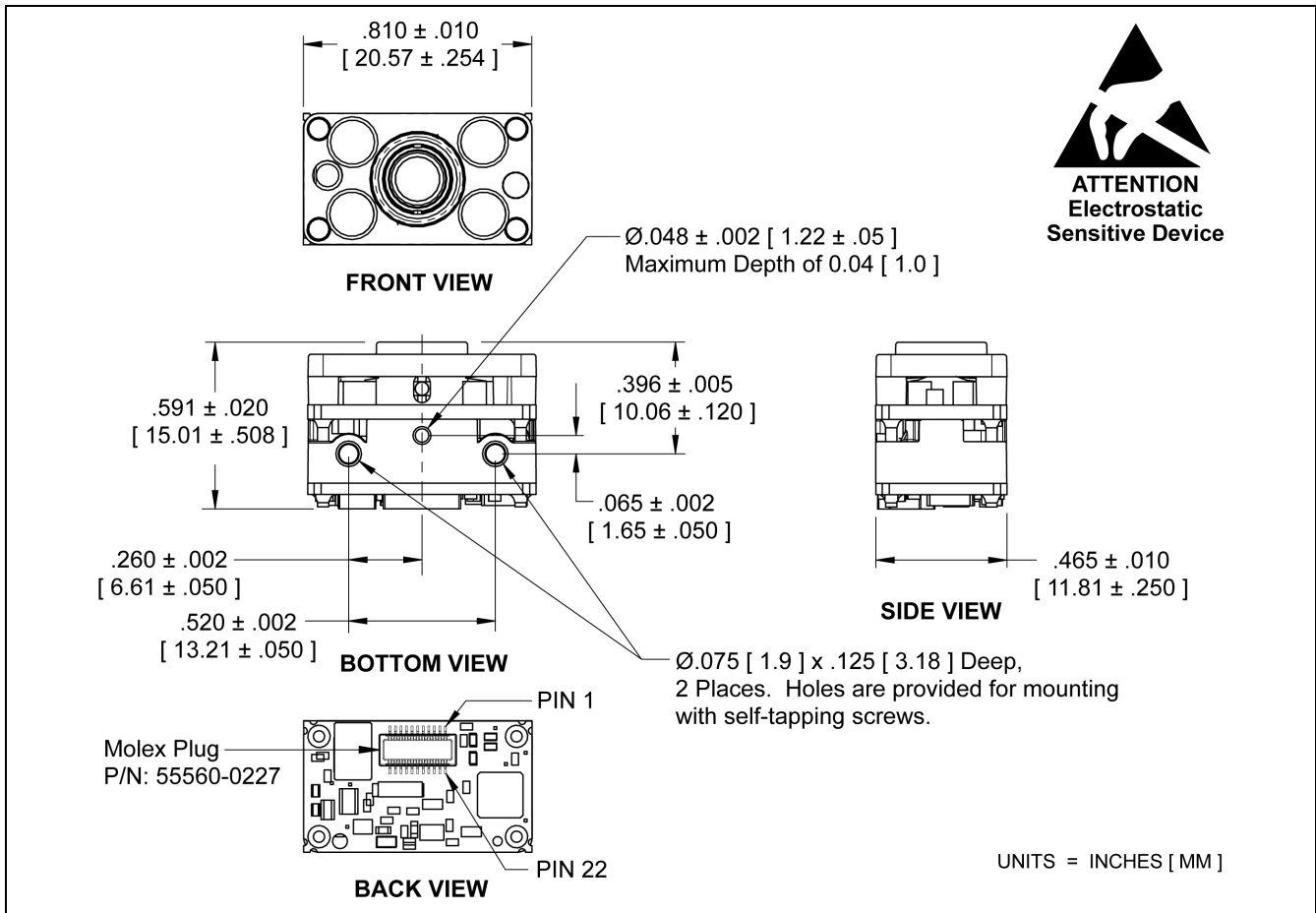


Figure 8. IS4910-00 / IS4911-00 Dimensions

## IS4910-01 / IS4911-01 Non-Decode Engine Dimensions

The -01 models include two  $\text{Ø} .075''$  [1.9 mm] blind holes for mounting the engine with self-tapping screws. Two additional  $\text{Ø} .098'' \pm .002$  [2.5 mm  $\pm .05$  mm] clearance holes are provided as a secondary mounting option. The clearance holes are located on tabs that extend from the sides of the engine's chassis. A keying location point is provided on the bottom of the engine to assist with alignment.

**Warning:** The limited warranty (on page 52) is void if the following recommendations are not adhered to when mounting the engine.

When securing the engine with self-tapping screws:

- Use M2.2 x 4.5 Philips Pan Head, Type AB, Steel, Zinc Clear, Trivalent self-tapping screws.
- Do not exceed 1.75 +0.5 in-lb [2.02 +6 cm-kg] of torque during screw installation.
- Use a minimum mount thickness of 0.3 mm.
- Use safe ESD practices when handling and mounting the engine.

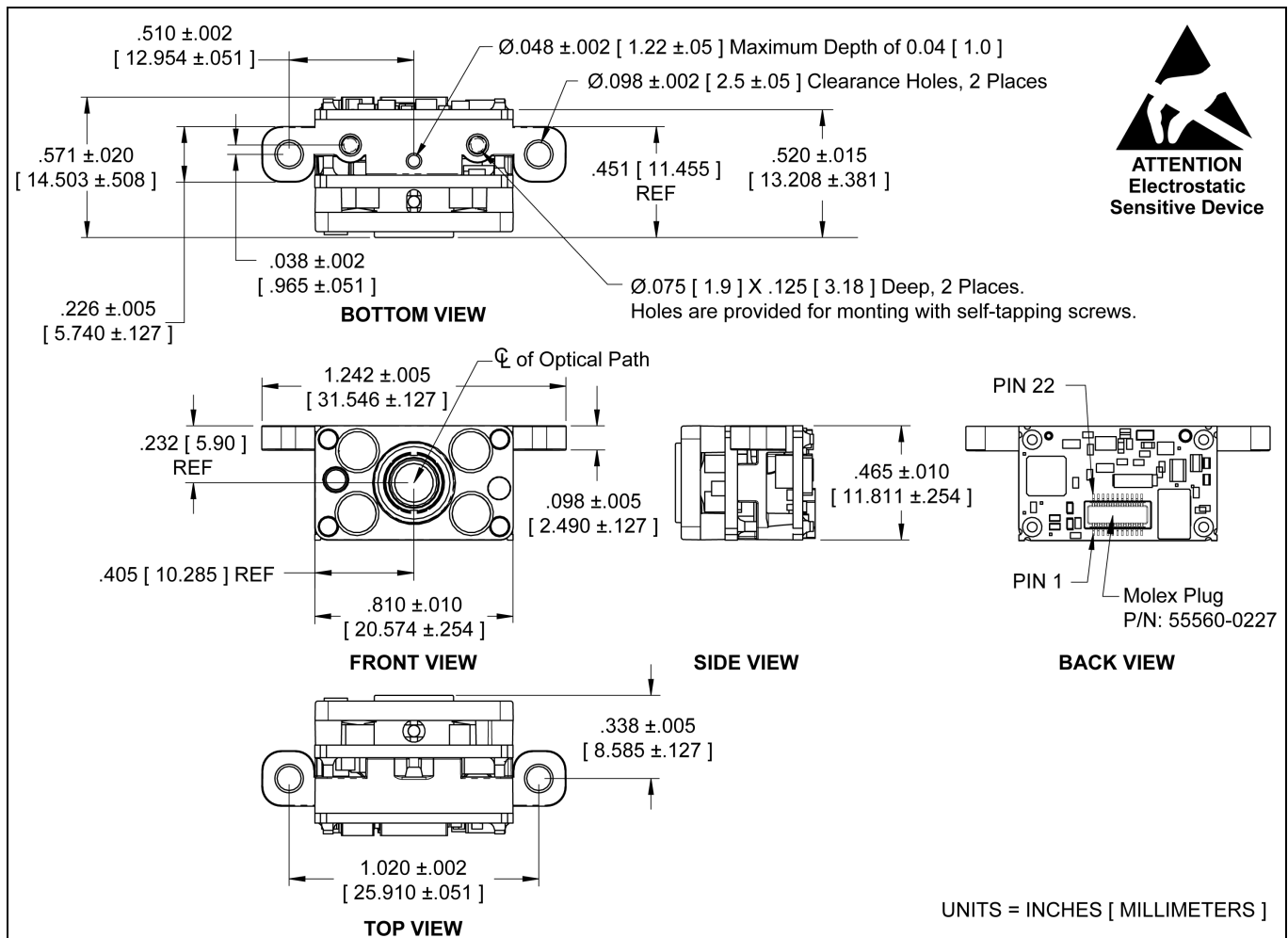


Figure 9. IS4910-01 / IS4911-01 Dimensions

---

## ***IS4910-02 / IS4911-02 Non-Decode Engine Dimensions***

The -02 models include two Ø .075" [1.9 mm] blind holes for mounting the engine with self-tapping screws. Two additional M2 x .4 threaded inserts are provided as a secondary mounting option. The threaded inserts are located on tabs that extend from the sides of the engine's chassis. A keying location point is provided on the bottom of the engine to assist with alignment.

**Warning:** The limited warranty (on page 52) is void if the following recommendations are not adhered to when mounting the engine.

When securing the engine with self-tapping screws:

- Use M2.2 x 4.5 Philips pan head, type AB, steel, zinc clear, trivalent self-tapping screws.
- Do not exceed 1.75 +0.5 in-lb [2.02 +6 cm-kg] of torque during screw installation.
- Use a minimum mount thickness of 0.3 mm.
- Use safe ESD practices when handling and mounting the engine.

When securing the engine by utilizing the M2 threaded inserts:

- Use M2 x 0.4 Philips Pan Head, Type AB, Steel, Zinc Clear, or equivalent screws.
- Do not exceed 2.5 in-lb [2.88 cm-kg] of torque during screw installation.
- Use a minimum mount thickness of 0.3 mm.
- Use safe ESD practices when handling and mounting the engine.

See Figure 10 on page 9 for detailed engine dimensions.

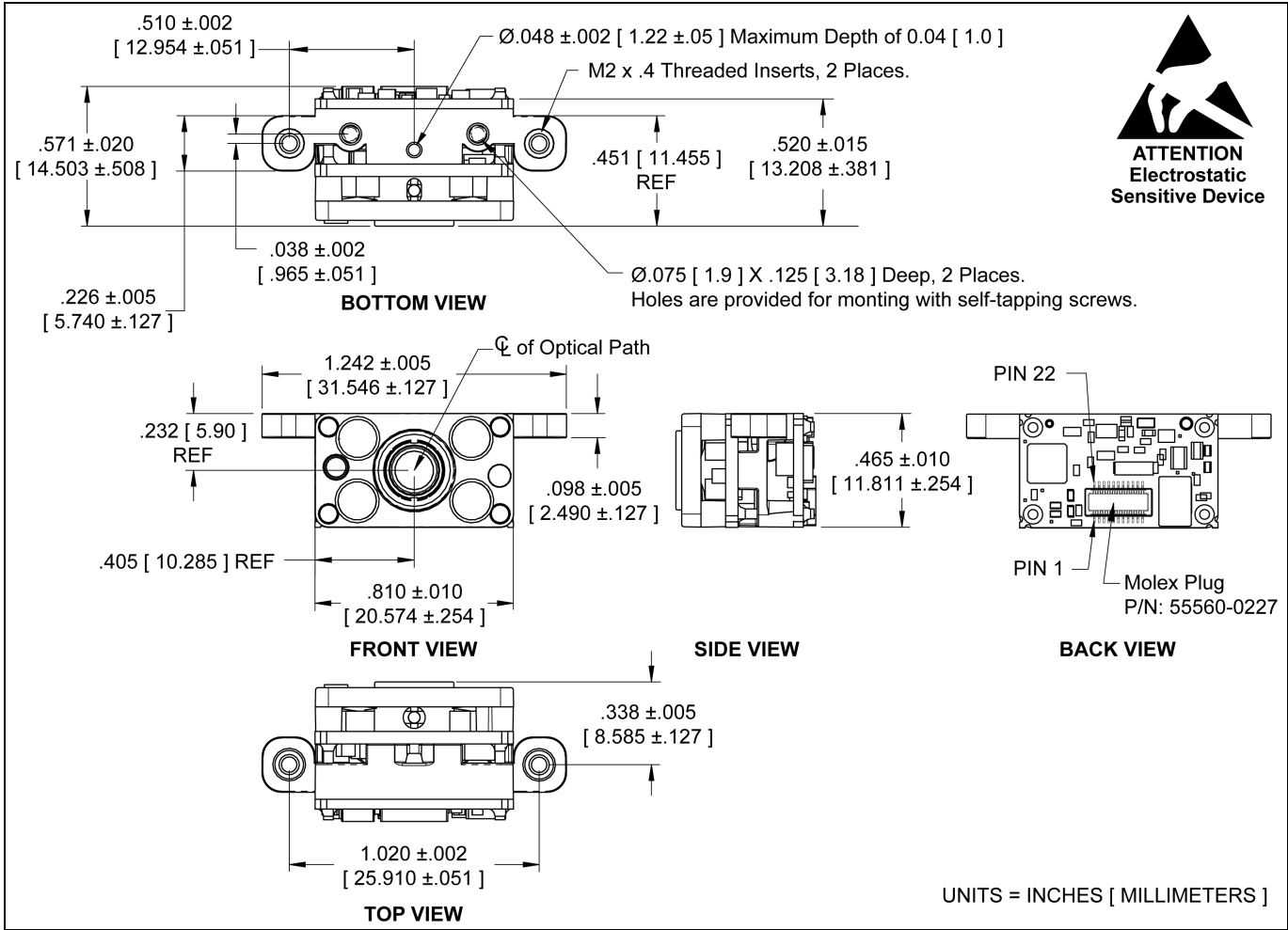


Figure 10. IS4910-02 / IS4911-02 Dimensions

## Decode Printed Circuit Board Dimensions

Both the TTL Level RS232 decode board and the USB decode board have two  $\varnothing 0.098$ " [2.489 mm] clearance holes for M2.2 mounting hardware. Always use safe ESD practices when handling and mounting the decode board.

### TTL Level RS232

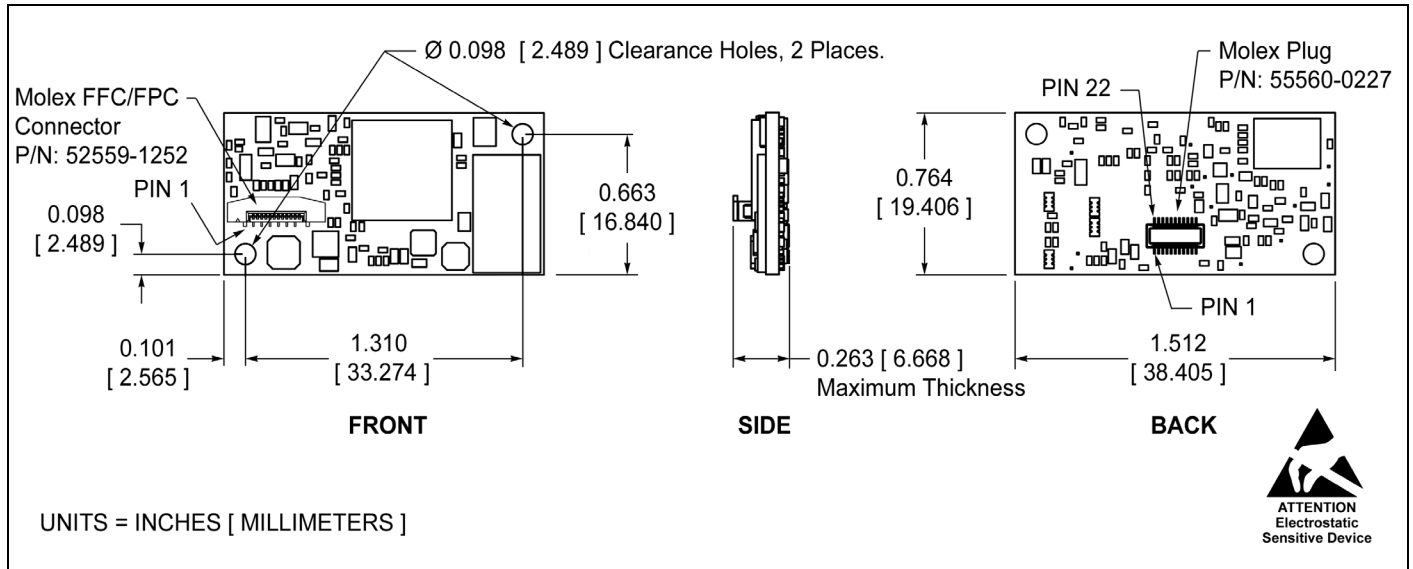


Figure 11. TTL Level RS232 Decode Board

### USB

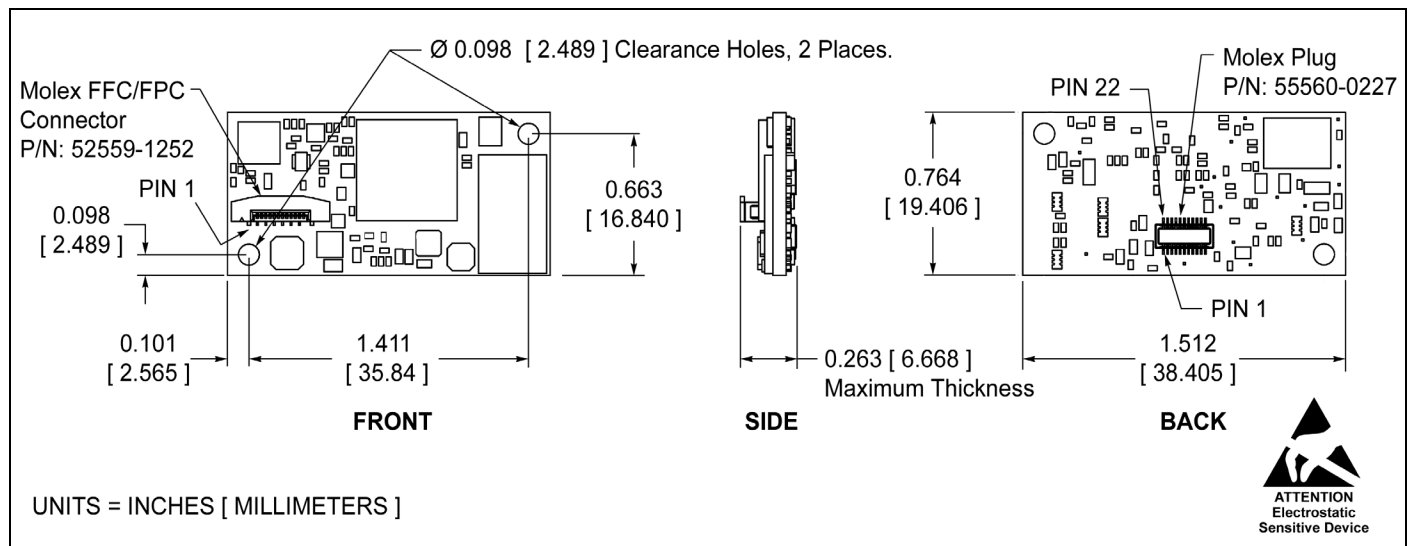


Figure 12. USB Decode Board Dimensions



## IS4920-2 / IS4921-2 Bracketed Decode Engine Dimensions

The bracketed decode engine includes two  $\text{\O} 0.097$ " [2.464 mm] blind holes for mounting the engine with self-tapping screws. Two additional M2 x .4 threaded inserts are provided as a secondary mounting option. The threaded inserts are located on tabs that extend from the sides of the engine's chassis. A keying location point is provided on the bottom of the engine to assist with alignment.

**Warning:** The limited warranty (on page 52) is void if the following recommendations are not adhered to when mounting the engine.

When securing the engine by utilizing the M2 threaded inserts:

- Use M2 x 0.4 Philips Pan Head, Type AB, Steel, Zinc Clear, or equivalent screws.
- Do not exceed 2.5 in-lb [2.88 cm-kg] of torque when securing the engine module to the host.
- Use a minimum mount thickness of 0.3 mm.
- Use safe ESD practices when handling and mounting the engine.

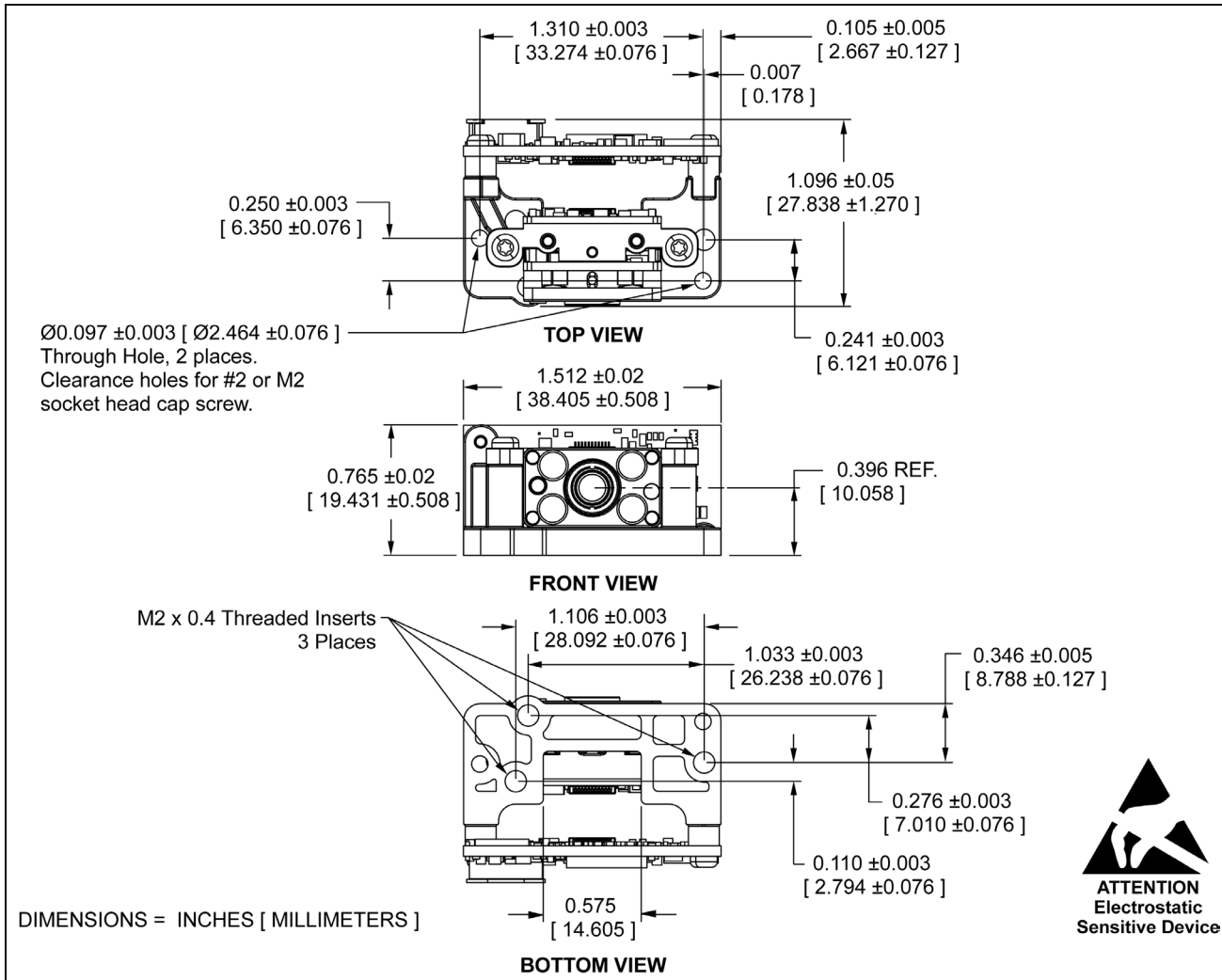


Figure 13. IS4920 / IS4921 Bracketed Decode Engine Dimensions

---

## ***Enclosure Specifications***

The imaging engine was specifically designed for integration into custom housings for OEM applications. The imaging engine's performance will be adversely affected or permanently damaged when mounted in an unsuitable enclosure.

**Warning:** The limited warranty (on page 52) is void if the following considerations are not adhered to when integrating the area-imaging engine into a system.

### ***Electrostatic Discharge (ESD) Cautions***



All engines and decode boards are shipped in ESD protective packaging due to the sensitive nature of the exposed electrical components.

- ALWAYS use grounding wrist straps and a grounded work area when unpacking and handling the engine.
- Mount the engine in a housing that is designed for ESD protection and stray electric fields.

ESD has the ability to modify the electrical characteristics of a semiconductor device, possibly degrading or even destroying the device. ESD also has the potential to upset the normal operation of an electronic system, causing equipment malfunction or failure.

### ***Airborne Contaminants and Foreign Materials***

The imaging engine has very sensitive miniature electrical and optical components that must be protected from airborne contaminants and foreign materials. In order to prevent permanently damaging the imaging engine and voiding the limited warranty (on page 52), the imaging engine enclosure must be:

- Sealed to prevent infiltration by airborne contaminants and foreign materials such as dust, dirt, smoke, and smog.
- Sealed to protect against water, humidity, and condensation.

Refer to page 15 for information on power and thermal considerations.

---

## ***Output Window Properties***

An improperly placed window has a serious potential to reduce the imaging engine's performance. Careful consideration must be made when designing the output window's distance and angle relative to the imaging engine's camera aperture.

Follow these guidelines when designing the output window.

- The output window material should have a spectral transmission of at least 85% from 580 nm to 680 nm and should block shorter wavelengths.
- The output window should have a 60-40 surface quality, be optically flat, clear, and free of scratches, pits, or seeds. If possible, recess the window into the housing for protection or apply a scratch resistance coating (see *Output Window Coatings* below).
- Apply an anti-reflective coating to the window surfaces to reduce the possibility of reflective light interfering with the engine's performance.
- The clear aperture of the output window should extend beyond the Field of View. Refer to page 14 and pages 33 - 34 for Field of View specifications.
- The window size must accommodate the illumination and targeting areas shown on page 14.
- The window must be parallel to the engine face.
- The distance from the engine face to the inside surface of the window of the enclosure should be minimized and should not exceed 0.5 mm (0.02") due to possible specular reflections from internal area illumination.

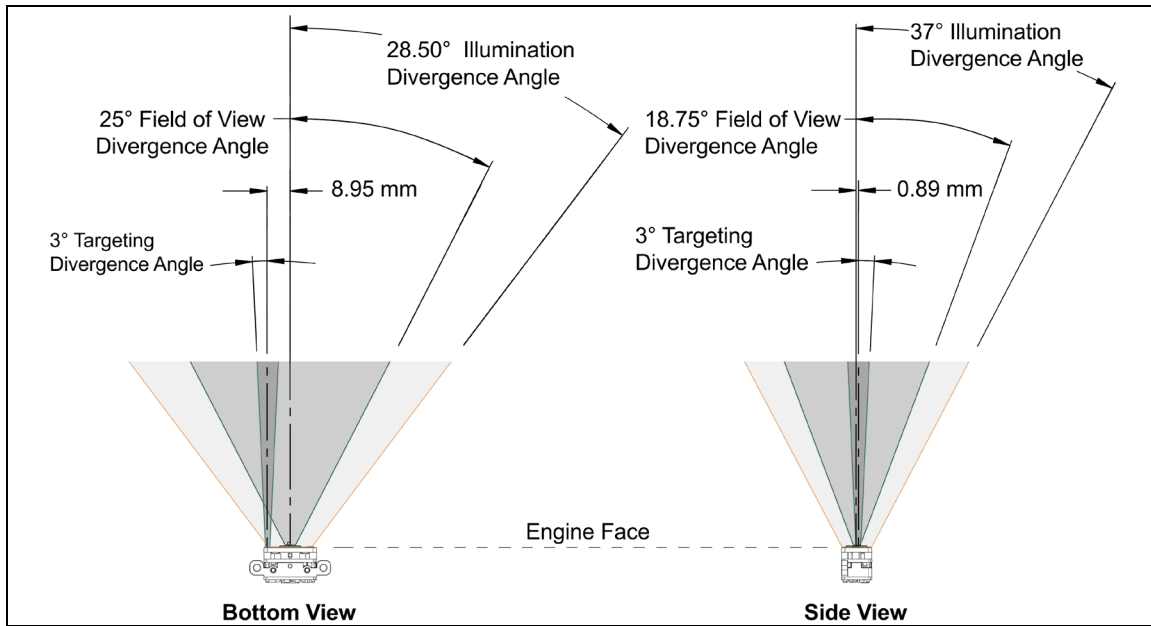
## ***Output Window Coatings***

- **Anti-Reflection**  
An anti-reflective coating can be applied to the inside and/or outside of the window to reduce the possibility of internal beam reflections interfering with the performance of the engine. If an anti-reflective coating is applied, the coating is recommended to be on both sides of the window providing a 0.5% maximum reflectivity on each side from 600 - 700 nanometers at the nominal window tilt angle. The coating must also meet the hardness adherence requirements of MIL-M-13508.
- **Polysiloxane Coating**  
Applying a polysiloxane coating to the window surface can help protect the window from surface scratches and abrasions that may interfere with the performance of the engine. Recessing the window into the housing can also provide added protection against surface damage such as scratches and chips. If an anti-reflective coating is used, there is no need to apply a polysiloxane coating.

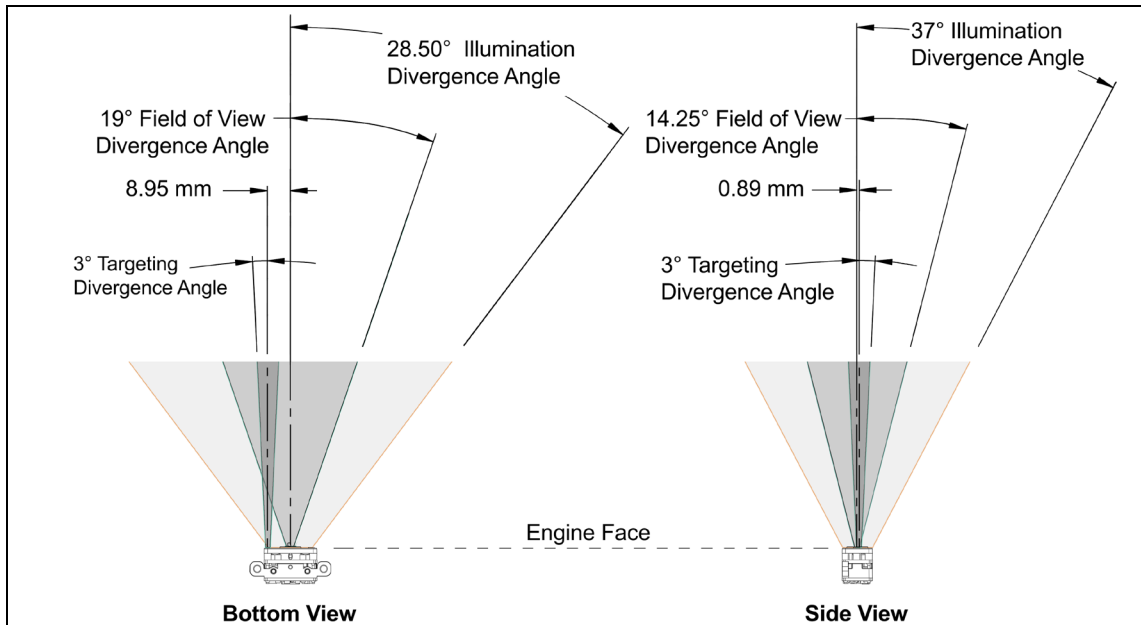
## Optical Clearance Specifications

The window size and enclosure design must provide unobstructed clearance for the *illumination and targeting areas* shown below in figures 14 and 15 to avoid optical interference that decreases the engine's performance.

### IS4910



### IS4911



# System Considerations

In order to ensure proper operation of the decode engine's electrical system; care must be taken to ensure the following requirements are met.

## **Power Supply\***

The decode engine is powered from the host device via the VIN and GND pins of the ZIF connector on the decode board. This voltage must be maintained within the specified voltage range at the decode board (see electrical specifications on page 38). Voltage drops in the host flex cable must be taken into account. The power must be clean and heavily decoupled in order to provide a stable power source.

**Note:** The power supply must be able to handle dynamic current loads because the input current will increase considerably when the illumination LEDs are enabled.

## **Host Flex Cable**

The host flex cable is used to carry power and data signals between the decode engine and the host system. The flex cable should allow for minimal voltage drop and maintain a good ground connection between the host and the decode engine. In terms of grounding and voltage drop, a shorter cable is better.

In addition to power, the flex cable will also carry the digital signals required for communication. The cable design is especially important in the case of USB due to the relative high speed of the USB signals. The impedance of the cable should match, or be as close as possible to, the impedance of the USB driver (approximately 45 ohms per trace).

The routing of the host flex cable also plays a critical role in the system design. The cable should be routed away from high frequency devices since these frequencies can couple onto the flex cable and cause potential data corruption or unwanted electromagnetic interference, EMI.

## **Power Sequencing\***

The decode engine is powered from the VIN power signal on the ZIF connector on the decode board. Most of the host signals (signals present on the ZIF connector) are relative to this voltage. Not all of these signals are overvoltage tolerant thus; care must be taken to ensure that the relationship between the VIN and the host signals are always met (see electrical specifications on page 38).

## **Thermal Considerations**

The decode engine is qualified over the specified operational temperatures (0°C to 40°C) for all operating modes. Make sure ambient temperatures do not exceed this range in order to guarantee operation. Operating the decode engine in continuous mode for an extended period may produce considerable heating. This mode should be limited and sufficient airflow should be provided whenever possible to minimize internal heating. Excessive heating may degrade images and potentially damage the engine.

\* See page 42 for additional information on electrical specifications.  
See pages 42 and 46 for additional information on the engine pinouts and flex cable pinouts.

# Theory of Operation

## Overview

The IS4920 decode imaging engine series is ideal for integration into data terminals and other small devices. The high-quality images produced by the imaging engine can be used for decoding bar codes, image upload, signature capture, document lifting and reading OCR fonts.

The decode engine consists of two main system components: the a non-decode imaging engine, which utilizes a high-resolution CMOS image sensor, and a small decode board that contains a powerful microprocessor and the firmware to control all aspects of the engine's operations and enabling communication with the host system over the standard set of communication interfaces.

The model IS492x-xx103 provides communication with the host system over TTL-level RS232 communication interface.

The model IS492x-xx38 provides communication with the host system over USB. It can be configured for the following protocols of USB communication:

- USB Keyboard Emulation Mode (default)
- USB Serial Emulation Mode

The system hardware architecture of the decode engine is shown in the figure below.

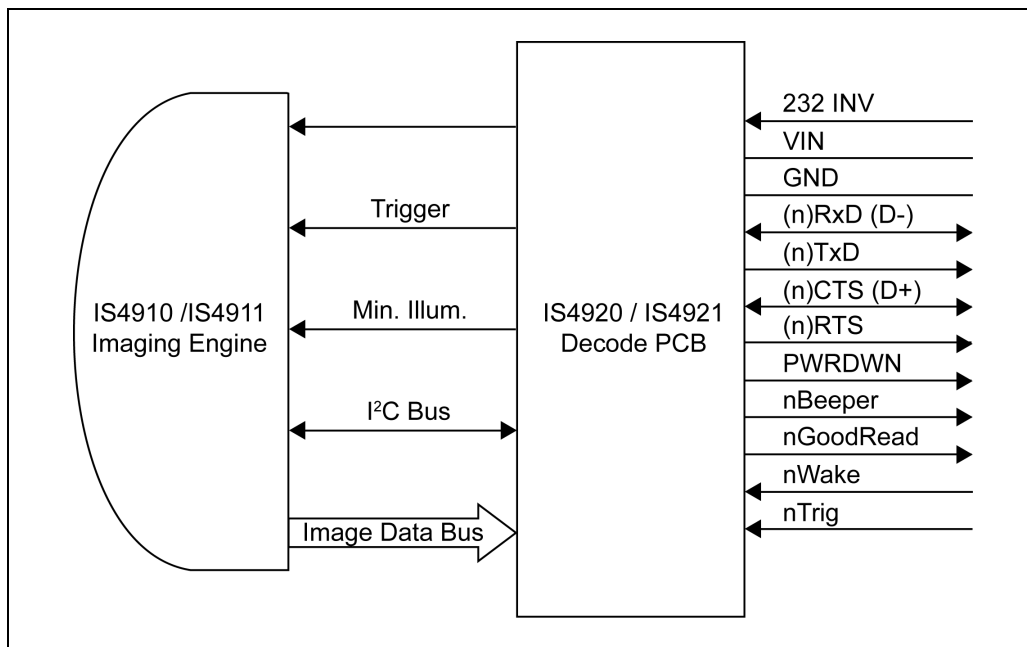


Figure 16. IS4920 / IS4921 System Architecture

## Host Interface Signals

The host interface signals are described in the table below.

Pin#	TTL RS232	USB	Description
1	232INV	NC	Input: TTL RS232 polarity control with 32k ohm pull-up. Connect to ground for UART to UART signal polarity. Pull up to $V_{in}$ for standard TTL RS232 polarity.
2	$V_{in}$	$V_{in}$	Power: Supply voltage input (3V to 5.5V)
3	GND	GND	Ground: Power and signal ground.
4	(n)RxD	D-	Input: TTL Level RS232 Receive data input, weak pull up to $V_{in}$ . Polarity determined by Pin1. Bidirectional: USB D- Signal
5	(n)TxD	<reserved>	Output: TTL Level RS232 transmits data. Polarity Determined by Pin 1.
6	(n)CTS	D+	Input: TTL level Clear to Send, weak pull up to $V_{in}$ . Polarity configurable via software. Bidirectional: USB D+ signal
7	(n)RTS	<reserved>	Output: TTL level RS232 Request to Send. Polarity configurable via software.
8	PWRDWN	PWRDWN	Output: Open drain, 100K pull up to $V_{in}$ ; active high indicates that the IS4920 is in Power Down Mode.
9	nBEEPER	nBEEPER	Output: Open drain, 100K pull up to $V_{in}$ ; active low signal capable of sinking current. PWM controlled signal can be used to drive an external beeper.
10	nGoodRead	nGoodRead	Output: Open drain, 100K pull up to $V_{in}$ ; active low signal for sinking current of a Good Read LED circuit.
11	nWAKE	nWake	Input: Weak pull up to $V_{in}$ ; active low, the signal can be used to bring the engine out of Power Down (TTL RS232 version only) or Sleep Mode (TTL RS232 and USB versions).
12	nTrig	nTrig	Input: Weak pull up to $V_{in}$ ; active low, the signal can be used as a trigger input to activate the IS4920.

---

Since many host systems and applications have unique formats and protocol requirements, the decode engine supports a wide range of configurable features. These features may be selected by scanning a corresponding configuration bar code from the MetroSelect Single-Line Configuration Guide or Area Imaging Bar code Supplemental Configuration Guide. Both guides are available for download at [www.honeywellaidc.com](http://www.honeywellaidc.com) under the IS4920 product page.

## ***Usage of the Host Interface Signals***

In the default “multi-try” trigger mode of operations, the scanning engine is activated by the nTrig signal, which must be kept active (low) until the successful scan is achieved, as indicated by the nGoodRead signal.

Upon a successful scan, the decode engine asserts the nGoodRead signal and keeps it asserted (low) for the duration of transmission of the decoded data to the host, or for the minimum of 100 msec (configurable to 50 msec), which coincides with the duration of the nBeeper signal.

The nGoodRead and nBeeper signals are driven with LVC family open drain outputs and are pulled up on the decode board with 100K resistors to VIN. The default state of these pins is Hi-Z (pulled up via 100K) and these signals are capable of sinking up to 24mA each when driven to the low state. For beeper applications, care must be taken to ensure that inductive spikes do not cause the voltage on the lines to exceed the maximum voltage of 5.5V.

**Warning:** The nGoodRead and nBeeper signals are not current limited. The external host circuitry connected to these pins must ensure that the current is limited to 25mA.

At any given time, the decode engine can be in one of the following power modes, see page 20 for descriptions:

- Boot Mode
- Operating Mode
- Configuration Mode 1
- Configuration Mode 2
- Idle Mode
- Presentation Wakeup Mode
- Sleep Mode
- Power-down Mode (TTL Only)
- Suspend Mode (USB Only)

When the decode engine is in the Sleep or Presentation Wakeup Mode, the nWake or nTrig signals can be used to wake up the engine.

The nWake signal wakes up the engine and turns the engine into the Idle Mode, which in the TTL RS232 version enables communication with the host for a short period of time defined by the value of the sleep timeout, which is set to one second by default.

**Note:** In the USB decode engines with USB Serial Emulation Mode activated; communication with the host is enabled even when the engine is in the Sleep or Presentation Wakeup Mode.



The nTrig signal not only wakes the engine up, but also immediately activates and turns the engine into the Operating Mode.

Either nWake or nTrig signals can be used to restart the TTL RS232 scanning engine when the engine is in Power-down Mode, which is indicated by the asserted (high) PWRDWN signal.

The PWRDWN pin is used to indicate when the decode engine is in various operating modes such as Power Down, Suspend, and Boot.

**Note:** The output signals from the decode engine can experience analog behavior when VIN is initially applied or removed due to the supply voltage ramping up or down. Care must be taken to ensure that this behavior does not adversely affect the host System. Special attention must be given to the PWRDWN Pin. When power is initially applied, the output state of this line will be indeterminate for about 10mS until the USB controller exits reset. The state of this pin should be disregarded during this time. The following waveforms show several signals when VIN is first applied (Figure 17) and when VIN is removed (Figure 18).

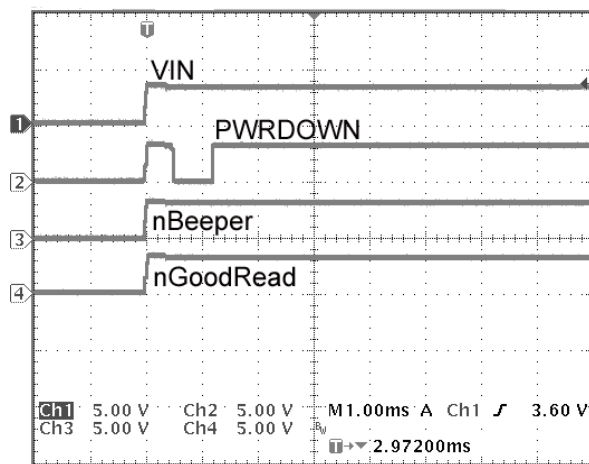


Figure 17. VIN First Applied (USB)

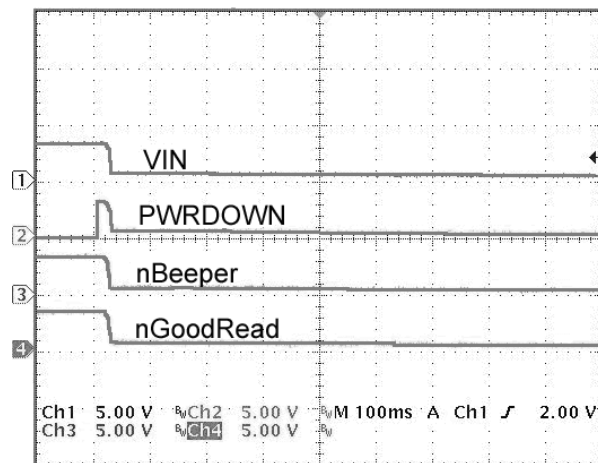


Figure 18. VIN Removed (USB)

---

## ***Power Mode Descriptions***

### ***Boot Mode***

The engine is booting up.

PWRDWN Pin State: Asserted (HIGH).

All bar code scanning by:

Trigger: Not Working

Remote Activation USB: Not Working

Remote Activation TTL: Not Working

Responsiveness: Not Working

Serial Program Mode: Not Working

Transition *to* Boot Mode:

- The TTL RS232 engine is turned to Boot Mode from Power Down Mode when the power is applied AND upon reception of the nTrig or nWake signals.
- The USB engine enters Boot Mode upon completion of USB enumeration.
- The engine can turn itself to Boot Mode from Operating Mode or Idle Mode upon some internal event, such as at the end of the software upgrade procedure.

At the end of the boot-up cycle the engine turns to the Idle Mode and de-asserts the PWRDWN pin.

### ***Operating Mode***

The engine is acquiring and processing images or running other tasks.

PWRDWN Pin State: De-asserted (LOW).

All bar code scanning by:

Trigger: Not Working

Remote Activation USB: Not Working

Remote Activation TTL: Not Working

Responsiveness: Not Working

Serial Program Mode: Not Working

Transition *to* Operating Mode:

- The engine is turned to Operating Mode from Idle, Sleep, or Presentation Wakeup Modes upon the reception of the nTrig signal.
- The engine can be turned to Operating Mode from Idle Mode (or Sleep Mode in USB version) upon the reception of a special single-byte serial command from the host. The byte value is configurable.
- The engine is turned to Operating Mode from the Presentation Wakeup Mode upon the object detection event.

---

## **Configuration Mode 1**

The engine is in configuration mode or updating firmware.

PWRDWN Pin State: De-asserted (LOW).

All bar code scanning by:

Trigger: Not Working

Remote Activation USB: Not Working

Remote Activation TTL: Not Working

Responsiveness: Not Working

Serial Program Mode: Not Working

Transition to Configuration Mode 1:

- The engine is turned to Configuration Mode 1 using MetroSet2 AutoSet to upload/download configuration.
- The engine is turned to Configuration Mode 1 using MetroSet2 AutoSet to update main board or I/O board firmware.
- The engine is turned to Configuration Mode 1 using MetroVision to transfer an image from the engine to the PC.

---

## **Configuration Mode 2**

The engine is in serial programming mode.

PWRDWN Pin State: De-asserted (LOW).

Non-programming bar code scanning by:

Trigger: Not Working

Remote Activation USB: Not Working

Remote Activation TTL: Not Working

Responsiveness: Not Working

Serial Program Mode: Not Working

Programming bar code scanning by:

Trigger: Working

Remote Activation USB: Working

Remote Activation TTL: Working and will not go to Sleep

Responsiveness: No delay, but can go into Idle or Presentation Wakeup Modes

Serial Program Mode: Working

Transition to Configuration Mode 2:

- The engine is turned to Configuration Mode 2 after scanning in the *Enter / Exit Configuration Mode* bar code while in Operating Mode or Idle Mode.
- The engine is turned to Configuration Mode 2 after entering *Enter / Exit Configuration Mode* serial programming string while in Operating Mode or Idle Mode.
- The engine is turned to Configuration Mode 2 after scanning a configuration bar code while in Operating Mode or Idle Mode, but not while in Configuration Mode 2.

---

## **Idle Mode**

The engine is not operating, but not sleeping and is fully powered. The CPU and image sensor are in the Idle Mode, the wakeup from which does not require the image sensor reprogramming.

PWRDWN Pin State: De-asserted (LOW).

Non-programming bar code scanning by:

Trigger: Working

Remote Activation USB: Working

Remote Activation TTL: Working

Responsiveness: No Delay

Serial Program Mode: Working

Transition to Idle Mode:

- The engine is turned to Idle Mode from Operating Mode immediately when no tasks are running in the engine.
- The engine is turned to Idle Mode from Sleep or Presentation Wakeup Modes upon the reception of the nWake signal.

## **Presentation Wakeup Mode**

The Presentation Wakeup Mode replaces the Idle Mode for an engine with Object Detection and Presentation Mode turned on. The engine normally enters Idle Mode after exited Operating Mode, Configuration Mode or Boot Mode with no pending operation.

PWRDWN Pin State: De-asserted (LOW).

Non-programming bar code scanning by:

Trigger: Working

Remote Activation USB: Working

Remote Activation TTL: Working

Responsiveness: Costs a few milliseconds due to exiting of Object Detection.

Serial Program Mode: Working

Transition to Presentation Wakeup Mode:

- The engine is turned to Presentation Wakeup Mode any time the engine tries to enter Idle Mode, if the engine is in Presentation Mode with the Presentation Wakeup feature enabled in NOVRAM. The Presentation Mode and Presentation Wakeup feature together overrides the Idle Mode and will enter Presentation Mode instead.

---

## ***Sleep Mode***

The engine is sleeping, but is fully powered. The CPU is in sleep mode. The image sensor is in standby mode, the wakeup from the Sleep Mode requires the image sensor reprogramming (which is done automatically in the engine software).

PWRDWN Pin State: De-asserted (LOW).

Non-programming bar code scanning by:

Trigger: Working

Remote Activation USB: Working

Remote Activation TTL: Not Working

Responsiveness: Costs tens of microseconds; Remote activation does not work for TTL

Serial Program Mode USB: Working

Serial Program Mode TTL: Not Working

Transition to Sleep Mode:

- The engine is turned to Sleep Mode from Idle Mode upon the expiration of the “sleep” timeout, which is set to one second by default. The “sleep” timeout is restarted every time the engine enters the Idle Mode.
- The engine can be turned to Sleep Mode from Operating Mode or Idle Mode immediately upon the reception of a special single-byte serial command from the host. The byte value is configurable.

## ***Power Down Mode (TTL RS232 Only)***

The power of the engine is turned off.

PWRDWN Pin State: Asserted (HIGH).

Non-programming bar code scanning by:

Trigger: Not Working / But able to reboot engine

Remote Activation USB: N/A

Remote Activation TTL: Not Working

Responsiveness: Requires complete reboot (Require toggling of nTrig or nWake pin)

Serial Program Mode: Not Working

Transition to Power Down Mode:

- The engine is turned to Power Down Mode from Sleep Mode upon the expiration of the “power-down” timeout, which is set to 10 minutes by default. The “power-down” timeout is restarted every time the engine enters the Sleep Mode.
- The engine can be turned to Power Down Mode immediately upon the reception of a special single-byte serial command from the host. The byte value is configurable.

The engine can wake up from Power Down Mode and reboot:

- Upon reception of the nTrig or nWake signals.

---

## ***Suspend Mode (USB Only)***

The engine is in its lowest power consumption state.

PWRDWN Pin State: Asserted (HIGH).

Non-programming bar code scanning by:

Trigger: Not Working

Remote Activation USB: Not Working

Remote Activation TTL: N/A

Responsiveness: Requires complete reboot (Host controlled)

Serial Program Mode: Not Working

Transition *to* Suspend Mode:

- The engine is turned to Suspend Mode upon receiving the USB Suspend signal from the USB host.
- The engine can be turned to Suspend Mode any time (by the USB host).

The engine can wake up from Suspend Mode and reboot:

- Upon receiving the Resume signal from the USB host.

# Serial Configuration

The IS4920 series can be configured by scanning configuration bar codes<sup>†</sup> or by serial commands sent from the host device. With serial configuration, each command sent to the engine is the ASCII representation of each numeral in the configuration bar code (see Figure 19). The entire numeric string is framed with an ASCII [stx] and an ASCII [etx].



Figure 19.

## Example 1:

<u>Feature</u>	<u>Host Command</u>	<u>String Sent to the Engine - ASCII Representation (Hexadecimal Values)</u>
Disable Codabar	[stx]100104[etx]	02h 31h 30h 30h 31h 30h 34h 03h

If the command sent to the engine is valid, the engine will respond with an [ack]. *If the command sent to the engine is invalid, the engine will respond with a [nak] then automatically exit serial configuration mode. All the settings chosen in the failed serial configuration session will be lost.* There is a 20-second window between commands. If a 60-second timeout occurs, the engine will send a [nak].

To enter serial configuration mode, send the following command, [stx]999999[etx]. The engine will not scan bar codes while in serial configuration mode.

**Note:** Serial configuration mode uses the current Baud Rate, Parity, Stop Bits and Data Bits settings that are configured in the engine. The default settings of the engine are 9600 bits-per-second, no parity, 1 stop bit, 8 data bits, and no flow control. If a command is sent to the engine to change any of these settings, the change will not take effect until after serial configuration mode is exited.

To exit serial configuration mode, send the following command, [stx]999999[etx]. The engine will respond with an [ack]. Refer to Example 2 on page 27.

<sup>†</sup> Bar code configuration manuals are available for download from the IS4920 product page at [www.honeywellaidc.com](http://www.honeywellaidc.com).



**Example 2:**

The following sample illustrates the serial command sequence for configuring the engine for the factory default settings, disabling Code 128 scanning, and adding a “G” as a configurable prefix.

Commands for features that require sequences of multiple bar codes for activation (i.e. prefixes, suffixes, and timeout features) should be sent in the same order that they are normally scanned.

<u>Feature</u>	<u>Host Command</u>	<u>ASCII Representation</u>	<u>Engine Response</u>
Enter Configuration Mode	[stx]999999[etx]	02h 39h 39h 39h 39h 39h 39h 03h	[ack] or 06h
Load Defaults	[stx]999998[etx]	02h 39h 39h 39h 39h 39h 38h 03h	[ack] or 06h
Disable Code 128	[stx]100113[etx]	02h 31h 30h 30h 31h 31h 33h 03h	[ack] or 06h
Configure Prefix #1	[stx]903500[etx]	02h 39h 30h 33h 35h 30h 30h 03h	[ack] or 06h
Code Byte 0	[stx]0[etx]	02h 30h 03h	[ack] or 06h
Code Byte 7	[stx]7[etx]	02h 37h 03h	[ack] or 06h
Code Byte 1	[stx]1[etx]	02h 31h 03h	[ack] or 06h
Exit Configuration Mode	[stx]999999[etx]	02h 39h 39h 39h 39h 39h 39h 03h	[ack] or 06h

**Abbreviated ASCII Table**

Character	Hex Value	Decimal Value
[STX]	02h	2
[ETX]	03h	3
[ACK]	06h	6
[NAK]	15h	21
0	30h	48
1	31h	49
2	32h	50
3	33h	51
4	34h	52
5	35h	53
6	36h	54
7	37h	55
8	38h	56
9	39h	57

# Operational Timing

The following section describes the timing associated with the various operating modes of the decode engine assembly including Power Up, Power Down, and Operating (from Idle or Sleep). The waveforms shown in this section assume VIN = 3.3V, nGoodRead pulled up with 10K resistor to VIN, and nBeeper pulled up with 10K resistor to VIN, unless otherwise noted.

## Power Up / Boot Up

The power up sequence of the decode engine depends on the interface type. For the USB version, a USB Microcontroller controls the power to the decoding platform and imaging engine via a power switch. When power is initially applied, only the USB controller is active and begins the process of enumeration. Once enumeration is complete, the USB controller turns power on to the imaging engine and decoding platform. As a result, powering up the engine is completely controlled by the on board USB controller per the USB specifications. In this version, only Idle and Sleep Modes are supported. For additional power savings, the unit must be placed in Suspend Mode per the USB specification. Figure 20 shows the power up sequence of the USB version of the decode engine.

**Note:** The PWNDWN signal remains high until the Decode platform transitions to Idle Mode and is ready to accept commands. In the USB version, the PWNDWN Pin will only be high during this boot up condition or when the Decode enters, Suspend Mode. From Figure 20, it can be seen that the entire boot up sequence takes approximately nine seconds.

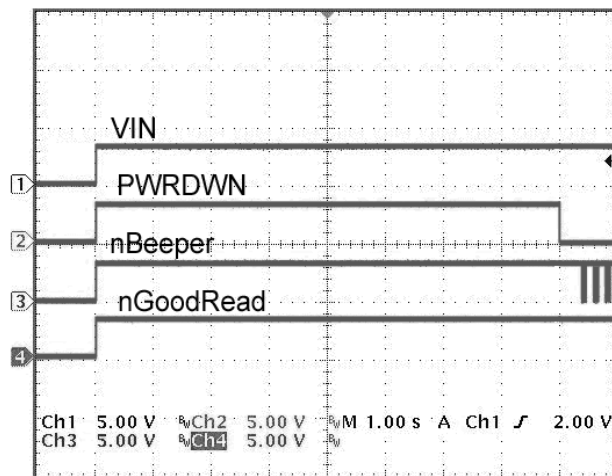


Figure 20. Power Up / Boot Up Sequence of USB Version

The TTL version of the decode engine does not have an on board microcontroller to control the power to the decode platform and imaging engine. As such, the TTL version can only enter Boot Mode in response to signals from the host (nTrig or nWake). When VIN is initially applied with the nWake and nTrig signals held high, the unit will be in the Power Down Mode. In this state, the PWRDWN signal will be high and all other output signals will be in their default state. By bringing either the nTrig or nWake signal low, power will be applied to the entire system and the unit will enter the Boot Mode. The nTrig or nWake signal will need to be held low continuously for approximately two seconds at which time the decode engine will take control of the internal power circuitry. At this point, the nTrig and nWake signals can be used with out interrupting the power. Figures 21 - 23 show the state several host signals when power is first applied and when the unit enters boot mode.

**Note:** The default state of TxD depends on the 232INV signal. When 232INV is low, the default state of TxD is high. When INV is high, the default state of TxD is low.

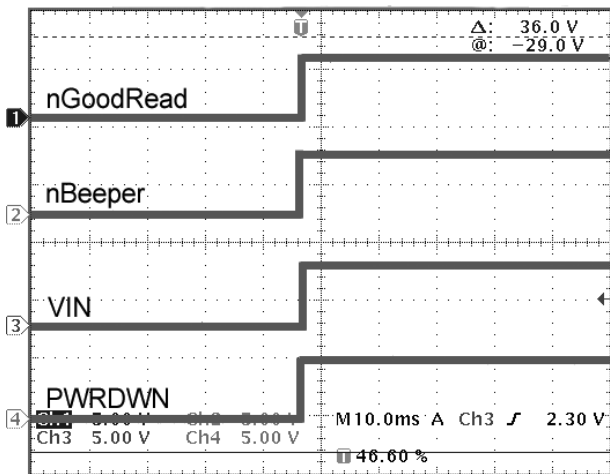


Figure 21. Power First Applied of TTL Version (Vin= 5V)

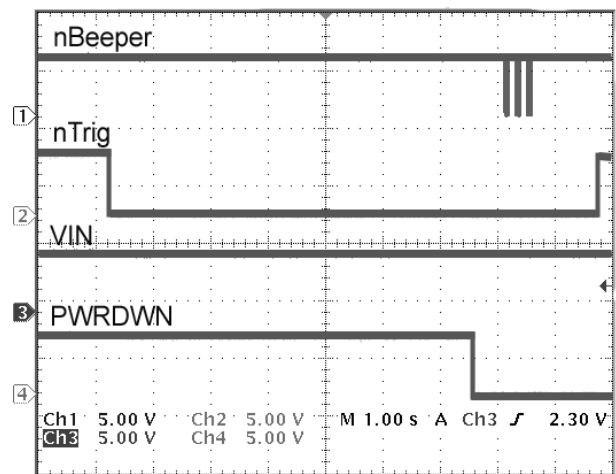


Figure 22. Boot Up Sequence of TTL Version (Vin= 5V) initiated by nTrig

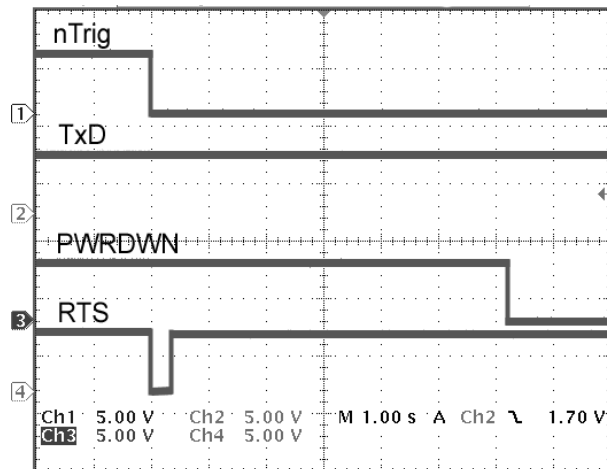


Figure 23. Transmit and RTS during Boot Up for TTL Version (Vin= 5V)

**Notes:** In Figure 21 , the nGoodRead, nBeeper, and PWRDWN signals are high while in the Power Down Mode.

The RTS Signal will be high in Power Down Mode regardless of the RTS polarity software configuration. Also, the RTS signal may have the incorrect polarity when the device first enters Boot Mode (Figure 23) or right before the unit enters Power Down Mode (Figure 24).

The USB version can be placed into Suspend Mode via the USB suspend signal for low current consumption. When this occurs, power to the decoding platform and imaging engine is removed. While in this state, nBeeper and nGoodRead will be in their default state (Hi-z with weak pull up). PWRDWN will be high and the USB data lines will be in the Suspend Mode.

## ***Power Down / Suspend / Power Removed***

At any time VIN can be completely removed from the decode engine however, care must be taken to avoid removing power during the boot up, flash upgrades, or configuration updates. Removing power during these times can result in the corruption of the flash memory. Figure 18 shows several host signals during a power removed condition for the USB version.

The TTL version enters into the Power Down Mode in which power to the decoding platform and imaging engine is removed. The decoding processor can initiate a Power Down sequence after a programmable time period has elapsed without any activity. Figure 24 shows the TxD, RTS, VIN, and PWRDWN signals when the TTL enters into Power Down Mode.

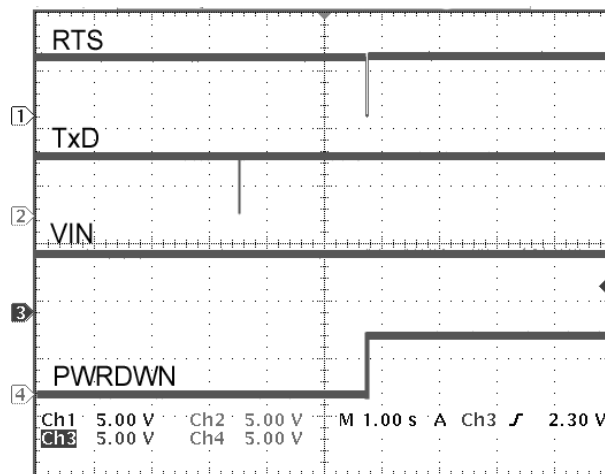


Figure 24. Power Down for TTL

## Decode Timing

Engine image acquisition or decoding can occur from either the Idle Mode or the Sleep Mode. The process is initiated by asserting the nTrig signal (or serial command when in the Idle Mode). Once the trigger signal is received, the image sensor is reset and image acquisition begins. During image acquisition, the illumination LEDs are enabled for a time determined by the FirstFlash circuitry on the non-decode engine. The image is then transferred to the processor and decoded. Upon decoding the image, the processor asserts the nGoodRead signal (low) and begins transmitting the decoded data. When the decode engine receives a trigger signal while in the Sleep Mode, an additional delay is needed for the processor exit Sleep Mode and reconfigures the sensor.

Figure 25 and Figure 26 show the amount of time required for decoding when a nTrig signal is asserted in both the Idle Mode and Sleep Mode.

**Notes:** The total image acquisition / decode time can be approximated by measuring the time from the nTrig signal going low to the nGoodRead signal going low. This time will vary slightly based on several factors including code quality, code type, and distance from the engine. The following waveforms show a typical condition.

The nTrig signal must be kept low for at least 20msec.

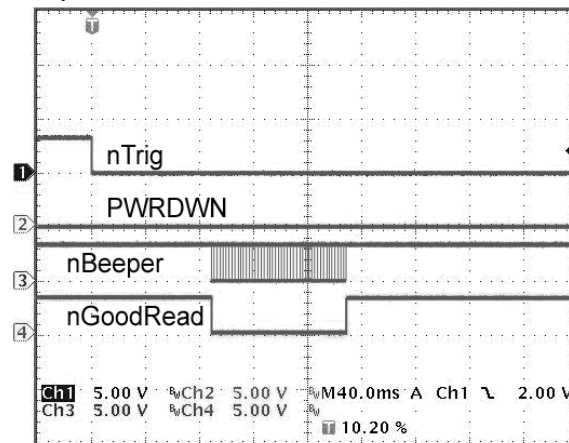


Figure 25. Decode time after receiving nTrig signal in Idle Mode.

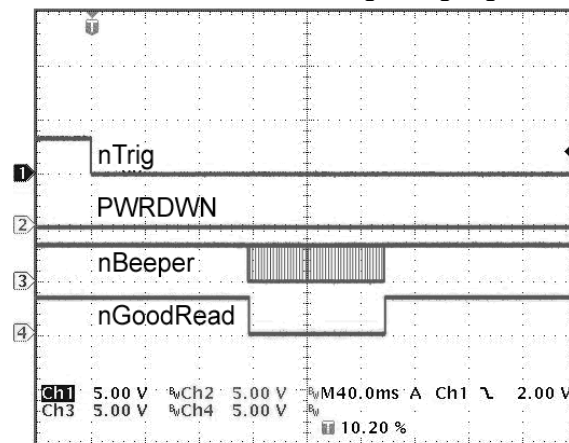


Figure 26. Decode time after receiving nTrig signal in Sleep Mode.

## Summary of Operation Timings

Operation Timing Specifications			
Parameter	Description	Typical	Relevant Note(s)
Tprw_up	Power Applied to Processor Ready Delay (USB)	6 seconds	Notes 4 and 5
Tprw_up_ttl	Trigger or Wake Low to Processor Ready Delay (TTL)	5 seconds	Note 4
Tdec_idle	Trigger Low to Decode complete Delay	90 msec	Notes 1 and 2
Tdec_sleep	Trigger Low to Decode complete Delay	120 msec	Notes 1 and 3
Trig_min	Minimum Duration of Trigger Signal	20 msec	
Trig_wake_min_pu	Minimum Activation Time for Trigger or Wake Signal to Power Up TTL Unit	2 seconds	
<p><b>Notes:</b></p> <ol style="list-style-type: none"> <li>1. Timing is the same for Both TTL or USB version</li> <li>2. Processor is in Idle Mode when nTrig signal is received</li> <li>3. Processor is in Sleep Mode when nTrig signal is received</li> <li>4. Typical time specified may vary depending on the enumeration time of the USB host.</li> <li>5. Typical times specified are valid for an IS4920 or an IS4921 with a firmware version of 15848 or higher. Units with a firmware version lower than 15848 may require up to 3 seconds of an additional time.</li> </ol>			

# Depth of Field vs. Bar Code Element

## IS4920

Bar Code Element Width			Depth of Field* (In the Field of View)		
			Start (From Engine Face)	End (From Engine Face)	Total
1D	0.127 mm	5 mil	55 mm (2.2")	130 mm (5.1")	75 mm (3.0")
	0.254 mm	10 mil	30 mm (1.2")	220 mm (8.7")	190 mm (7.5")
	0.330 mm	13 mil	25 mm (1.0")	310 mm (12.2")	285 mm (11.2")
PDF	0.170 mm	6.67 mil	45 mm (1.8")	155 mm (6.1")	110 mm (4.3")
	0.254 mm	10 mil	25 mm (1.0")	300 mm (11.8")	275 mm (10.8")
Data Matrix	0.254 mm	10 mil	40 mm (1.6")	85 mm (3.3")	45 mm (1.8")
	0.381 mm	15 mil	40 mm (1.6")	155 mm (6.1")	115 mm (4.5")
	0.508 mm	20 mil	45 mm (1.8")	330 mm (13.0")	285 mm (11.2")

\* Depth of field information is for reference only. Actual values may vary depending on testing conditions.

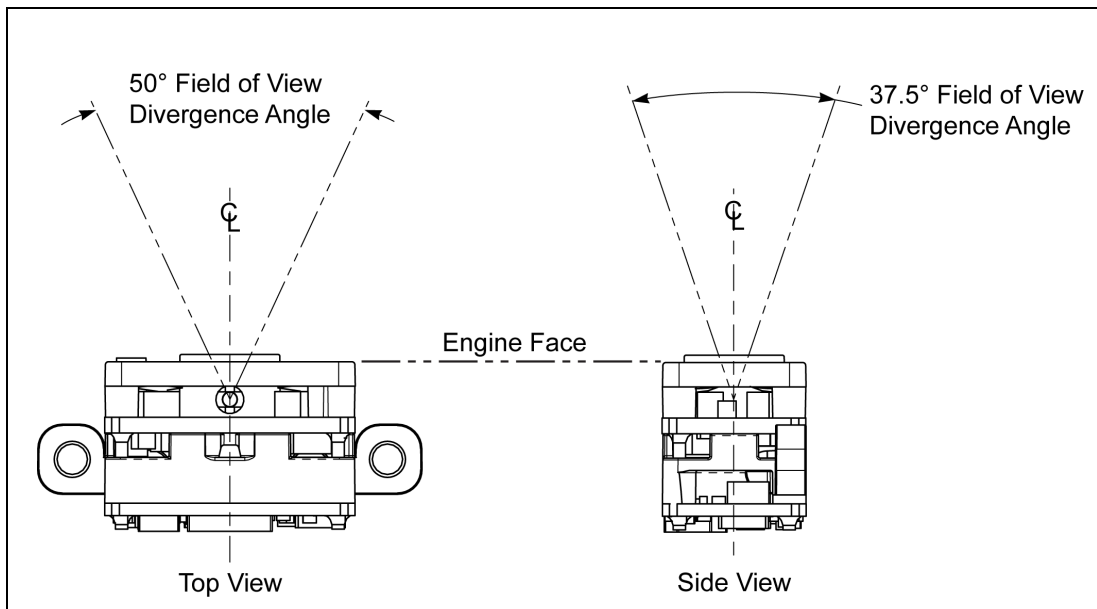


Figure 27. Field of View, Divergence Angle (model IS4910-01 shown)

## IS4921

Bar Code Element Width			Depth of Field* in the Field of View		
			Start (From Engine Face)	End (From Engine Face)	Total
1D	.076 mm	3 mil	68 mm (2.7")	105 mm (4.1")	37 mm (1.4")
	.127 mm	5 mil	50 mm (2.0")	120 mm (4.7")	70 mm (2.75")
	.330 mm	13 mil	50 mm (2.0")	170 mm (6.7")	120 mm (4.7")
PDF	.127 mm	5 mil	45 mm (1.8")	130 mm (5.0")	85 mm (3.2")
Data Matrix and QR	.127 mm	5 mil	75 mm (3.0")	115 mm (4.5")	40 mm (1.5")

\* Depth of field information is for reference only. Actual values may vary depending testing conditions.

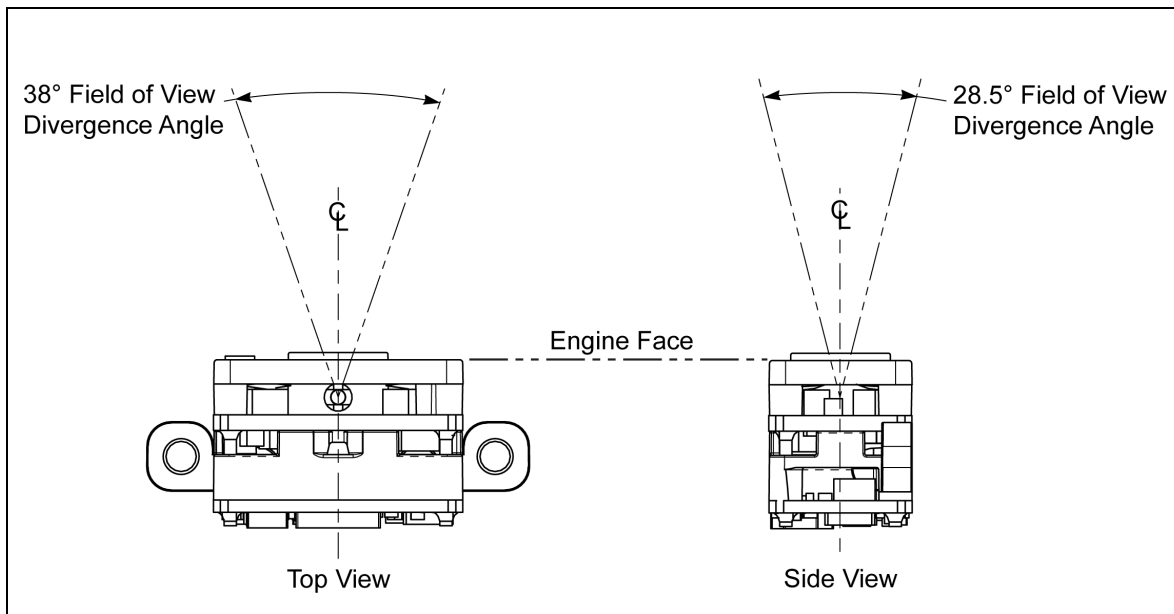


Figure 28. IS4911 Field of View, Divergence Angle (model IS4911-01 shown)



# Exposure Time for Image Acquisition

By default, the maximum exposure time for image acquisition is 8 ms. Reducing the exposure time for image acquisition may improve the reading performance of high-density bar codes for certain applications. Use the following bar codes to set the desired maximum exposure time.

Set Exposure Time to 1 ms



Set Exposure Time to 2 ms



Set Exposure Time to 3 ms



Set Exposure Time to 4 ms



Set Exposure Time to 5 ms



Set Exposure Time to 6 ms



Set Exposure Time to 7 ms



Set Exposure Time to 8 ms



# Design Specifications

## Operational

Light Source:	Four, 650 nm Red Light Emitting Diode LED	
Depth of Field:	IS4920	25 mm – 310 mm (1.0" to 12.2") for 0.330 mm (13 mil) 1D Bar Codes See page 33 for additional information on engine depth of field.
	IS4921	50 mm – 170 mm (2.0" to 6.7") for 0.330 mm (13 mil) 1D Bar Codes See page 34 for additional information on engine depth of field.
Field of View:	IS4920	50° Horizontal
		37.5° Vertical
	IS4921	38° Horizontal
		28.5° Vertical
Viewing Field Size:	IS4920	118.4 mm x 86.2 mm (4.7" x 3.4") at 127 mm (5.0") from the Face of the Engine
		236.8 mm x 172.4 mm (9.3" x 6.8") at 254 mm (10.0") from Face of the Engine
	IS4921	37 mm x 28 mm (1.45" x 1.08") at 80 mm (3.15") from the Face of the Engine
		78 mm x 58 mm (3.09" x 2.3") at 170 mm (6.69") from the Face of the Engine
Rotation Sensitivity:	360° Around the Optical Axis	
Minimum Element Width:	IS4920	.10 mm (4.0 mil) 1D, PDF
		.191 mm (7.5 mil) 2D
	IS4921	.063 mm (2.5 mil) 1D, PDF
		.10 mm (4.0 mil) 2D
Resolution:	1.2 mega pixels (1280 x 960)	
Symbologies Supported:	All standard 1D and 2D Bar Codes; Optional OCR fonts.	
Print Contrast:	20% Minimum	

---

## **Mechanical**

Dimensions:	See pages 6 - 8 for detailed specifications.
Weight:	< 14 g (.494 oz.)
Termination:	12-Pin, Molex FFC/FPC Connector (Molex P/N 52559-1252) See page 42 for engine pinouts. See page 46 for flex cable specifications.
Mounting:	See pages 6 - 11 for detailed specifications.
Keying Location:	See pages 6 - 11 for detailed specifications.

*FFC/FPC is a trademark of Molex, Inc., all rights reserved.*

## **Environmental**

Operating Temperature:	0°C to 40°C (32°F to 104°F)
Storage Temperature:	-20°C to 70°C (-4°F to 158°F)
See page 15 for additional information on thermal considerations.	
Humidity:	5% to 95% relative humidity, non-condensing
Light Levels:	0 - 110,000 Lux
Shock:	5 ft. (1.5 m)
Vibration Protection:	7G, 10 – 500 Hz
Contaminants:	See page 12.

## Electrical

Engine Input Voltage:	3.3VDC ~ 5.5VDC	
Typical Operating Current:	235 mA (continuous scan mode, VIN=3.3V)	
	<b>USB</b>	<b>TTL</b>
Peak Operating Current:	400 mA (typical VIN=3.3V @ 25°C)	400 mA (typical VIN=3.3V @ 25°C)
Idle Current:	160 mA (typical VIN=3.3V @ 25°C)	125 mA (typical VIN=3.3V @ 25°C)
Sleep Current:	65 mA (typical VIN=3.3V @ 25°C)	25 mA (typical VIN=3.3V @ 25°C)
Suspend Current (USB):	600 $\mu$ A* (typical VIN=3.3V @ 25°C)	N/A
Power Down Current (TTL):	N/A	500 $\mu$ A* (typical VIN=3.3V @ 25°C)
* Specifications are based on the assumption inputs are pulled high. If inputs are externally pulled low, the current through the pull up registers must be added to these numbers.		
See pages 50 - 51 for regulatory compliance information.		

## Detailed Electrical Specifications

Absolute Maximum Ratings			
Signal	Signal Description	MIN	MAX
Vinput †	Voltage Applied to Any input pin (except D+ and D-) *	-0.3V	5.5V
Voutput	Voltage Applied to Any output pin **	-0.3V	VIN + .3V

\* For USB version, Voltages on D+ and D- signal must conform to USB Specification

\*\* Voutput must be less than 5.5V for all pins

† If the Vinput signal is greater than VIN, current will flow from the input to the VIN pin through the pull-up resistors on the engine. In Suspend Mode, this may cause current to flow into the USB power. This is not recommended.

DC Operating Voltages				
Signal	Signal Description	MIN	MAX	Condition
VIN	Operating Voltage	3V	5.5V	
VIH(1)	Input High (RX, CTS)	2.5V		
VIL(1)	Input Low (RX, CTS)		.8V	
VIH(2)	Input High (TTL_INV, nWake)	.8xVIN		
VIL(2)	Input Low (TTL_INV, nWake)		.8V	
VIH(3)	Input High (Trigger)	.8xVIN		
VIL(3)	Input Low (Trigger)		.25V	
VOH(1)	Output High Voltage (TX,RTS)	.8xVIN		Isource = 16 mA
VOL(1)	Output Low Voltage (TX,RTS)		.14xVIN	Isink = 16 mA
VOH(2)	Output High Voltage (nBeeper, nGoodRead)	***	5.5V	
VOL(2)	Output Low Voltage (nBeeper, nGoodRead)		.6V	Isink = 25 mA
VOH(3)	Output High Voltage (Power down)	***	5.5V	
VOL(3)	Output Low Voltage (Power down)		.2V	Isink = 8 mA

\*\*\* PWRDWN, nGoodRead, and nBeeper are open drain outputs w/ 100K pull-ups to VIN. Actual VOH will be determined by the parallel resistance of the 100K pull up and any external impedance.

Current Draw @ 25°C					
Signal	Signal Description	USB		TTL	
		VIN = 3.3V	VIN = 5V	VIN = 3.3V	VIN = 5V
Continuous Scan mode	Average current draw during continuous scan mode*	235 mA	175 mA	200 mA	140 mA
Idle	Average current draw while in idle mode	160 mA	120 mA	125 mA	85 mA
Sleep	Average current draw while in sleep mode	65 mA	65 mA	25 mA	25 mA
Suspend Mode (USB)	Average current draw in USB suspend (USB version only)	600 µA	650 µA	N/A	N/A
Power Down Mode (TTL)	Average current draw in power down mode (TTL Version Only)	N/A	N/A	500 µA	500 µA

\* **Note:** Continuous Scan Mode current will vary based on object size, distance, and type. The numbers listed above are typical.

## Current Waveforms

Figure 29 - Figure 31 show typical current signature for the decode engine (USB version) in various operating modes.

**Note:** The next three waveforms are shown with  $V_{IN} = 3.3V$  and the output signals nBeeper and nGoodRead are pulled high externally through 10K resistors. Thus, these waveforms only account for the current drawn by the IS4920 circuitry and does not show additional current required for driving the LED or Beeper.

The IS4920 series engines do not have current limiting fuses. Care must be taken on the host side to prevent against over current conditions that could potential damage the host system.

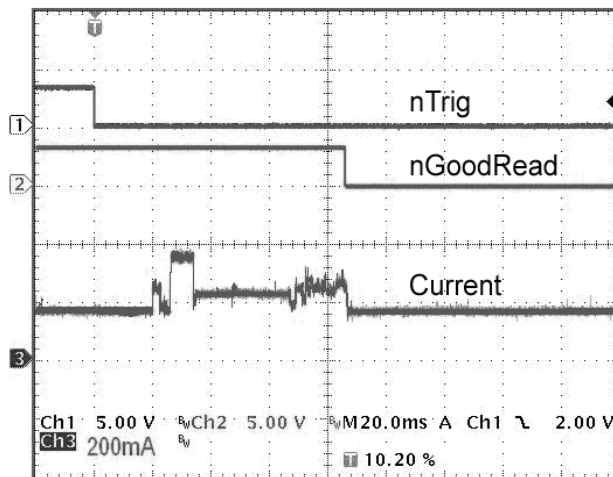


Figure 29. Single Image Decode Current Waveform (from Idle Mode)

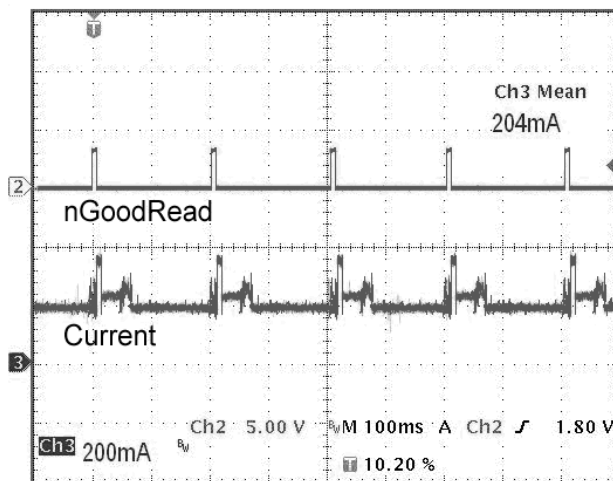


Figure 30. Continuous Image Decode Current Waveform ( $I_{ave} = 204mA$ )

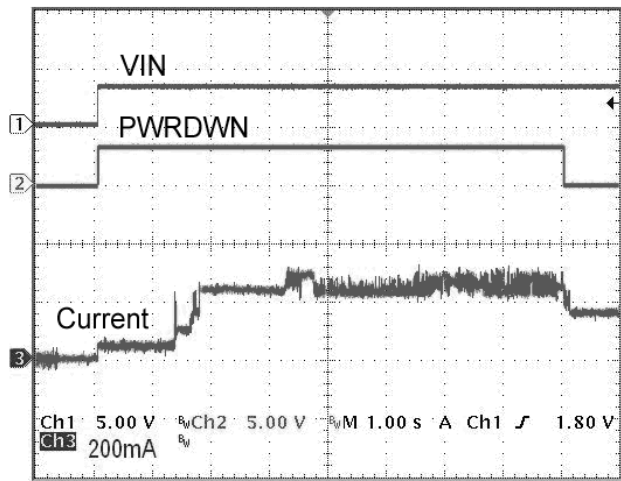


Figure 31. Power Up / Boot Up Current Waveform

# Imaging Engine and Decode PCB Terminations

## Imaging Engine Interface Connector

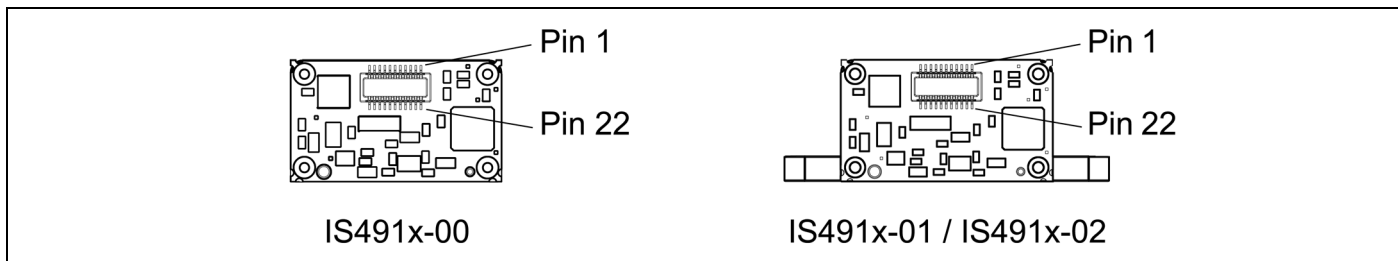


Figure 32. Imaging Engine Interface Connector

Pin	Signal Name	Function
1	Aimer	High enables Targeting LED (Input)
2	Illum_On	High forces on Illumination LEDs (Input), Wake up Engine
3	Trigger	Controls Integration and Illumination in Snapshot mode (Input)
4	SDA	I2C data (Bi-Directional) – Devices Functions as Auxiliary Devices
5	SCL	I2C clock (Bi-Directional) – Devices Function as Auxiliary Devices
6	VLED	Voltage Supply for Targeting and Area LEDs (3V - 5.5V)
7	D0	Pixel Data0 (LSB) (Output)
8	Vimager	Camera Voltage (3.1V - 3.5V)
9	D1	Pixel Data1 (Output)
10	D2	Pixel Data2 (Output)
11	D3	Pixel Data3 (Output)
12	PCLK	Pixel Clock (Output)
13	D7	Pixel Data7 (Output)
14	D6	Pixel Data6 (Output)
15	D5	Pixel Data5 (Output)
16	D4	Pixel Data4 (Output)
17	VSYNC	Vertical Sync (Output)
18	HSYNC	Horizontal Sync (Output)
19	GND	Power and Signal ground
20	Reserved	Terminate with Resistor, Pulled Low, or Leave Unconnected
21	GND	Power and Signal Ground
22	NC	No Connection

\* In the Phillips I2C specification auxiliary is defined as slave.



## Decode Board (USB & TTL) Interface Connector

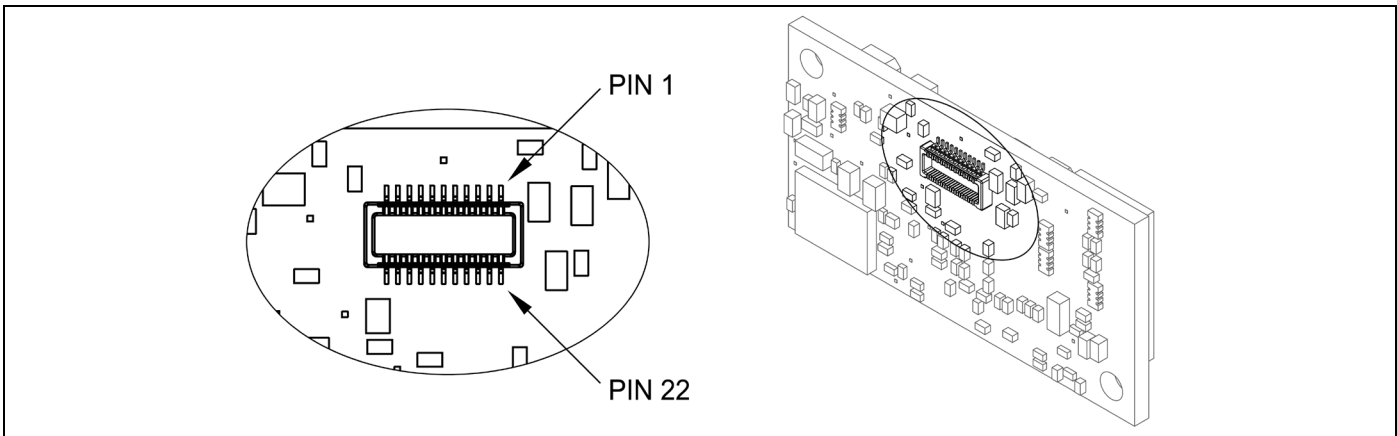


Figure 33. Decode Board Interface Connector

Pin	Signal Name	Function
1	GND	Power and Signal Ground
2	Reserved	Terminate with resistor, Pulled low, or Leave Unconnected
3	GND	Power and Signal Ground
4	HSYNC	Horizontal Sync (Output)
5	VSYNC	Vertical Sync (Output)
6	D4	Pixel Data4 (Output)
7	D5	Pixel Data5 (Output)
8	D6	Pixel Data6 (Output)
9	D7	Pixel Data7 (Output)
10	PCLK	Pixel Clock (Output)
11	NC	No Connection
12	D3	Pixel Data3 (Output)
13	D2	Pixel Data2 (Output)
14	D1	Pixel Data1 (Output)
15	Vimager	Camera Voltage (3.1V - 3.5V)
16	D0	Pixel Data0 (LSB) (Output)
17	VLED	Voltage supply for Targeting and Area LEDs (3V - 5.5V)
18	SCL	I2C clock (Bi-Directional) – Devices Function as Auxiliary Devices
19	SDA	I2C Data (Bi-Directional) – Devices Function as Auxiliary Devices
20	Trigger	Controls Integration and Illumination in Snapshot Mode (Input)
21	Illum_On	High Forces on Illumination LEDs (Input)
22	Aimer	High Enables Targeting LED (Input)

## Decode Board (USB) Output to Host Connector

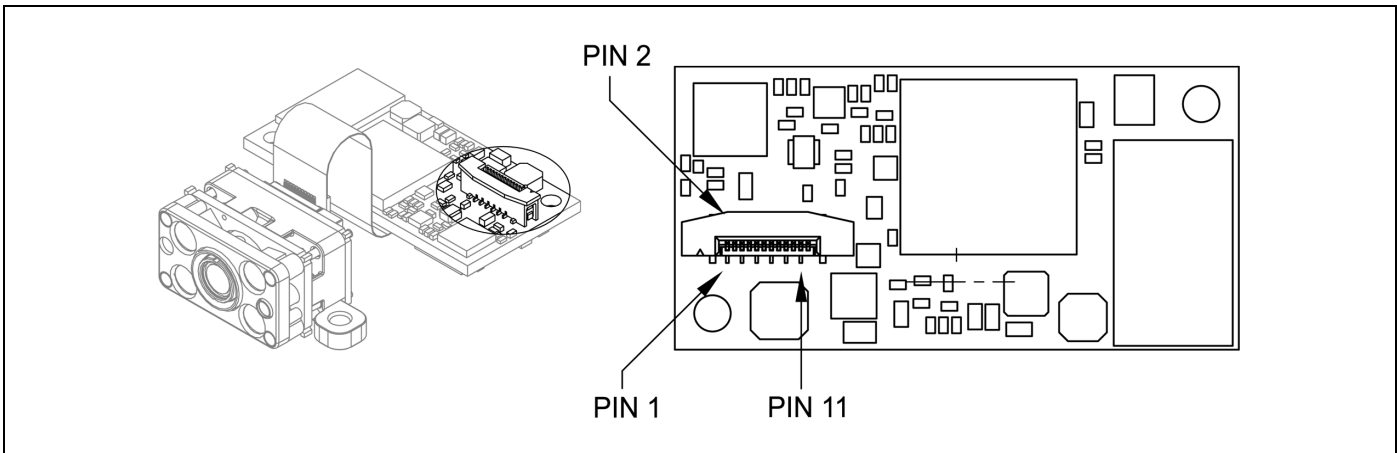


Figure 34. Decode Board (USB) Output Connector

Pin	Signal Name	Function
1	N/C	No Connection
2	Vin	Power: Supply voltage input (3V to 5.5V)
3	GND	Ground: Power and signal ground.
4	D-	Input: USB D- Signal
5	<reserved>	Pin Function Reserved.
6	D+	Input: USB D+ Signal
7	<reserved>	Pin Function Reserved.
8	PWRDWN	Output: active high = IS4920 is in power down mode.
9	nBEEPER	Output: active low signal capable of sinking current.
10	nGoodRead	Output: active low signal for sinking current (Good Read).
11	nWAKE	Input: Wakes engine from power-down or sleep mode.
12	nTrig	Input: Signal used as trigger input to activate the IS4920

## Decode Board (TTL) Output to Host Connector

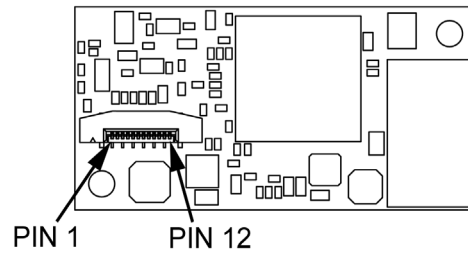


Figure 35. Decode Board (TTL) Output Connector

Pin	Signal Name	Function
1	232INV	Input: TTL RS232 polarity control with 32k ohm pull-up.
2	Vin	Power: Supply voltage input (3V to 5.5V)
3	GND	Ground: Power and signal ground.
4	(n)RxD	Input: TTL Level RS232 Receive data input.
5	(n)TxD	Output: TTL Level RS232 transmit data.
6	(n)CTS	Input: TTL level Clear to Send.
7	(n)RTS	Output: TTL level RS232 Request to Send.
8	PWRDWN	Output: active high = IS4920 is in power down mode.
9	nBEEPER	Output: active low signal capable of sinking current.
10	nGoodRead	Output: active low signal for sinking current (Good Read).
11	nWAKE	Input: Signal used to bring engine out of power-down.
12	nTrig	Input: Signal used as trigger input to activate the IS4920

# Flex Cable Specifications

## Flex Cable Pinout – Imaging Engine Connection

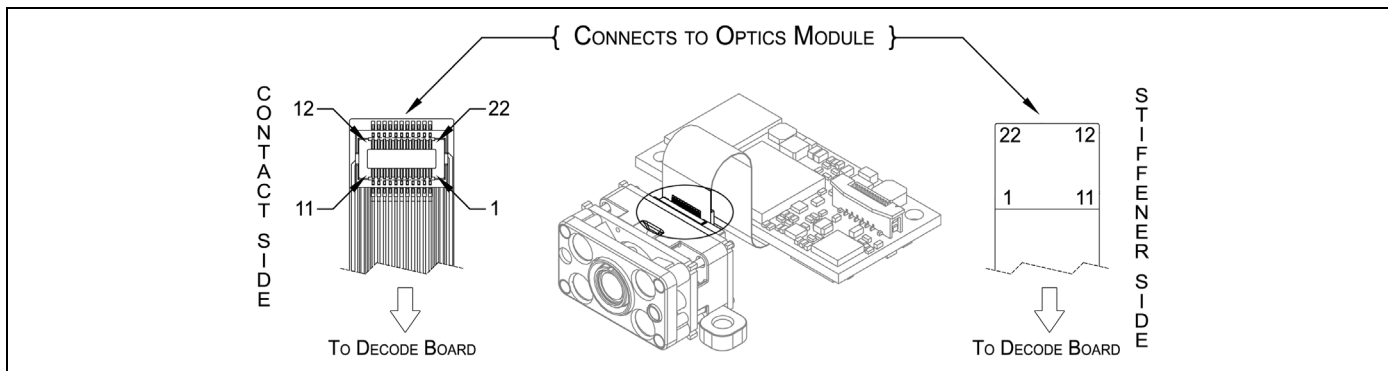


Figure 36. Flex Cable Pinout (Imaging Engine Connector End)

Pin	Signal Name	Function
1	Aimer	High enables Targeting LED (Input)
2	Illum_On	High forces on Illumination LEDs (Input), Wake up Engine
3	Trigger	Controls Integration and Illumination in Snapshot mode (Input)
4	SDA	I2C data (Bi-Directional) – Devices Functions as Auxiliary Devices
5	SCL	I2C clock (Bi-Directional) – Devices Function as Auxiliary Devices
6	VLED	Voltage Supply for Targeting and Area LEDs (3V - 5.5V)
7	D0	Pixel Data0 (LSB) (Output)
8	Vimager	Camera Voltage (3.1V - 3.5V)
9	D1	Pixel Data1 (Output)
10	D2	Pixel Data2 (Output)
11	D3	Pixel Data3 (Output)
12	PCLK	Pixel Clock (Output)
13	D7	Pixel Data7 (Output)
14	D6	Pixel Data6 (Output)
15	D5	Pixel Data5 (Output)
16	D4	Pixel Data4 (Output)
17	VSYNC	Vertical Sync (Output)
18	HSYNC	Horizontal Sync (Output)
19	GND	Power and Signal ground
20	Reserved	Terminate with Resistor, Pulled Low, or Leave Unconnected
21	GND	Power and Signal Ground
22	NC	No Connection

## Flex Cable Pinout – Decode Board Connection

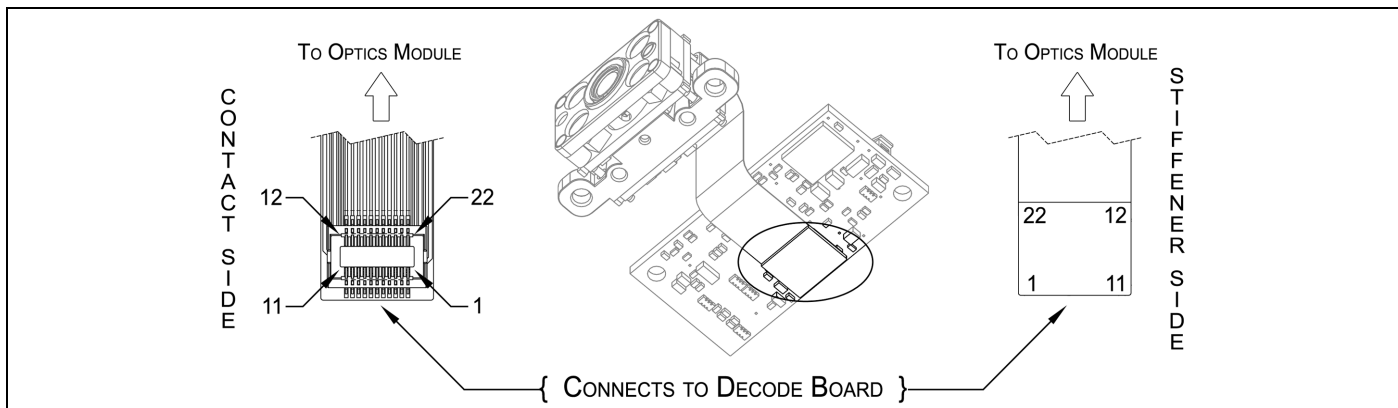


Figure 37. Flex Cable Pinout (Decode Connector End)

Pin	Signal Name	Function
1	GND	Power and Signal Ground
2	Reserved	Terminate with resistor, Pulled low, or Leave Unconnected
3	GND	Power and Signal Ground
4	HSYNC	Horizontal Sync (Output)
5	VSYNC	Vertical Sync (Output)
6	D4	Pixel Data4 (Output)
7	D5	Pixel Data5 (Output)
8	D6	Pixel Data6 (Output)
9	D7	Pixel Data7 (Output)
10	PCLK	Pixel Clock (Output)
11	NC	No Connection
12	D3	Pixel Data3 (Output)
13	D2	Pixel Data2 (Output)
14	D1	Pixel Data1 (Output)
15	Vimager	Camera Voltage (3.1V - 3.5V)
16	D0	Pixel Data0 (LSB) (Output)
17	VLED	Voltage supply for Targeting and Area LEDs (3V - 5.5V)
18	SCL	I2C clock (Bi-Directional) – Devices Function as Auxiliary Devices
19	SDA	I2C Data (Bi-Directional) – Devices Function as Auxiliary Devices
20	Trigger	Controls Integration and Illumination in Snapshot Mode (Input)
21	Illum_On	High Forces on Illumination LEDs (Input)
22	Aimer	High Enables Targeting LED (Input)

## Dimensions

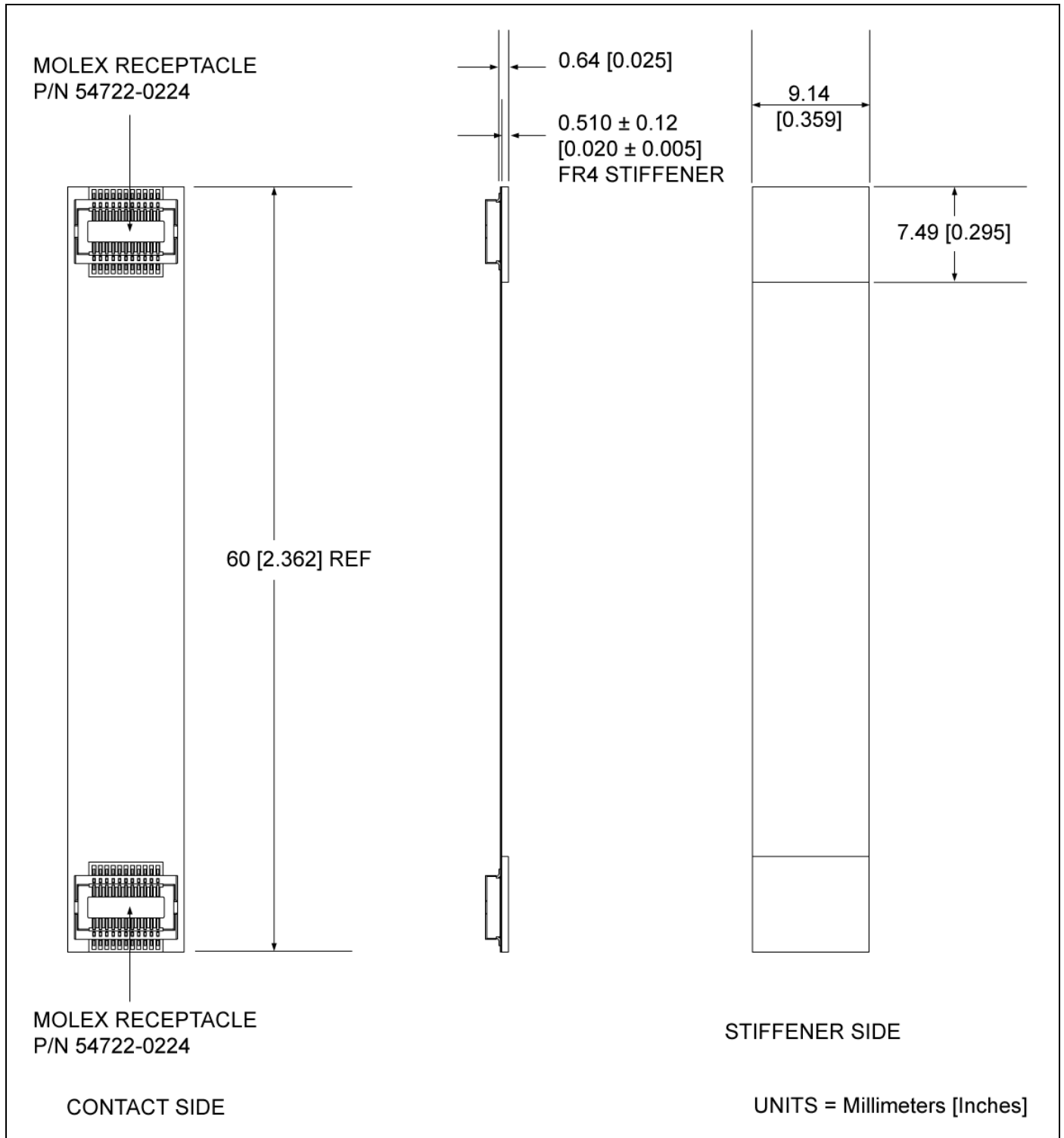



Figure 38. Flex Cable Dimensions, P/N 77-77101

 See installation warning on page 49.

## Installation Notes

### Note 1. Warning!

The flex cable must be installed in the orientation shown in Figure 39 and Figure 40. If the cable is incorrectly installed, the engine can be damaged, and the warranty voided, see page 52.

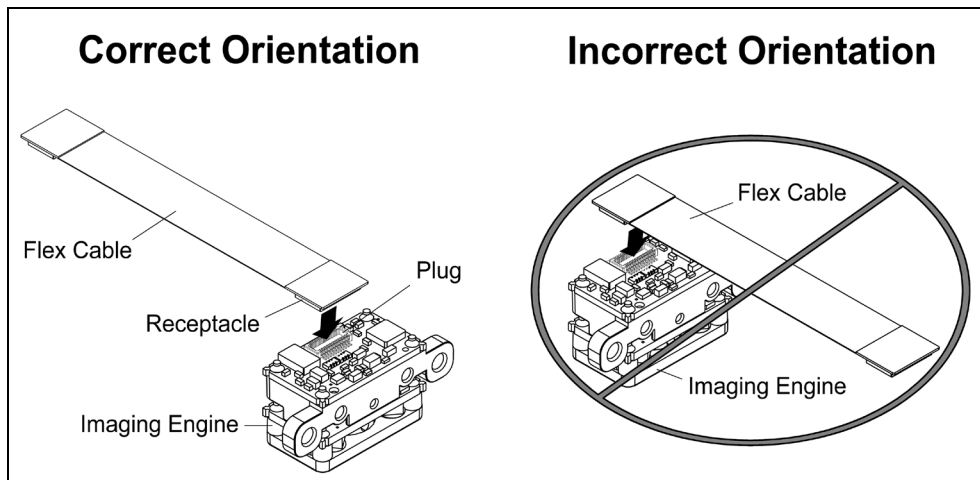


Figure 39. Flex Cable Orientation – Imaging Engine

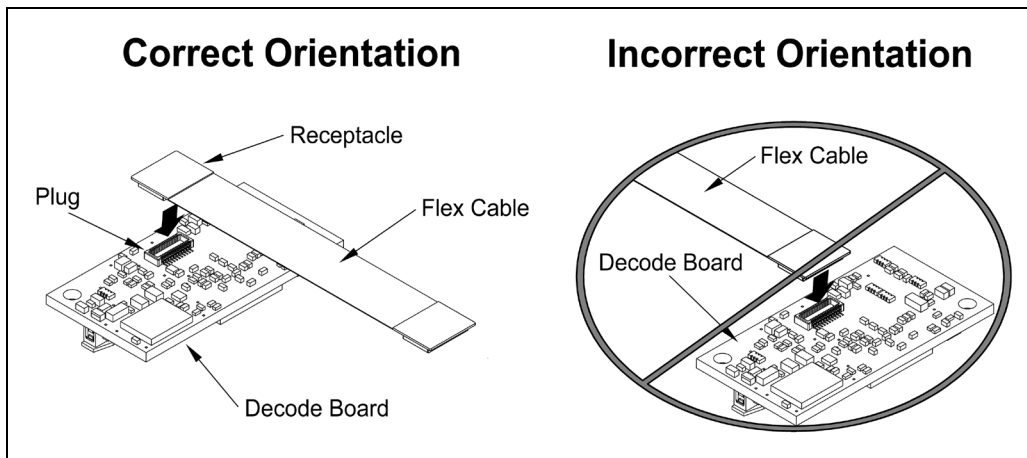


Figure 40. Flex Cable Orientation – Decode Board

**Note 2.** Proper installation of the flex cable is essential for engine performance. When installing the flex cable, verify that the flex cable receptacle is fully seated in the engine plug. To achieve a full connection, ensure that the alignment of the mating parts is not angled during installation. Flex cable P/N 77-77101 is designed with universal ends.

**Note 3.** Once installed, it is recommended that the flex cable be connected and routed securely in the enclosure to prevent loss of connection.

## Safety

The IS4920 Series area imaging engines are designed to meet the requirements of IEC Class 1 in accordance with IEC 60825-1:1993+A1+A2. IEC Class 1 is defined as follows:

The specifications required for agency approval are not obtainable until the IS4920 or IS4911 area imaging engine is used in its final configuration. Honeywell International Inc. is unable to fulfill these requirements because the imaging engine will operate differently depending upon where the engine is used as a component.

If the product containing the engine is to be used other than the United States, the manufacturer who incorporates the imaging engine into their product is responsible for fulfilling any regulatory compliance requirements for that country. Refer to one of the following sections for further explanation.

### ⚠ Caution

Use of controls or adjustments or performance of procedures other than those specified herein may result in hazardous radiation exposure. Under no circumstances should the customer attempt to service the LED engine. Never attempt to look at the LED beam, even if the engine appears to be nonfunctional. Never open the engine in an attempt to look into the device. Doing so could result in hazardous radiation exposure. The use of optical instruments with the LED equipment will increase eye hazard.

## Europe

The CE Mark is required on products that incorporate the IS4920 series engine if the products are to be imported into European Economic Area (EEA) countries. Use of the CE Mark requires compliance with directives and standards dependent upon the type of product. Information may be found at <http://europa.eu.int/comm/enterprise/newapproach/>.

### LED Safety

IEC 60825-1:1993+A1+A2,  
EN 60825-1:1994+A1+A2

Compliance with either of the standards listed above is required for the product to bear the CE mark.

**Note:** Non-EEA countries may impose additional testing/certification requirements.

### EMC

All combinations of IS4920 area imaging engines and associated electronics will require certification of compliance with the European EMC Directive. EMC compliance of finished products in Europe can be accomplished by the following method:

The manufacturer may certify to the EC's Electromagnetic Compatibility Directive 2004/108/EC. Compliance is required for the product to bear the CE Mark.

**Note:** Non-EEA countries may impose additional testing/certification requirements.

### Electrical Safety

The IS4920 engines are built to conform to the European Low Voltage Directive 2006/95/EC.





---

## ***United States***

### EMC

All combinations of imaging engines and associated electronics will require testing to insure compliance with the following Federal Communications Commission regulation: 47 CFR Part 15

**Note:** When using the imaging engine with RF equipment, modems, etc. may require examination(s) to the standard(s) for the specific equipment combination. It is the manufacturers' responsibility to comply with the applicable federal regulation(s).

## ***Canada***

### EMC

Products meeting FCC 47 CFR Part 15 will meet Industry Canada interference-causing equipment standard for digital apparatus, ICES-003. Additional testing is not required.

A written notice indicating compliance must accompany the apparatus to the end user. The notice shall be in the form of a label that is affixed to the apparatus. The notice may be in the form of a statement included in the user's manual if, because of insufficient space or other restrictions, it is not feasible to affix a label to the apparatus.

## Limited Warranty

Honeywell International Inc. ("HII") warrants its products and optional accessories to be free from defects in materials and workmanship and to conform to HII's published specifications applicable to the products purchased at the time of shipment. This warranty does not cover any HII product which is (i) improperly installed or used; (ii) damaged by accident or negligence, including failure to follow the proper maintenance, service, and cleaning schedule; or (iii) damaged as a result of (A) modification or alteration by the purchaser or other party, (B) excessive voltage or current supplied to or drawn from the interface connections, (C) static electricity or electro-static discharge, (D) operation under conditions beyond the specified operating parameters, or (E) repair or service of the product by anyone other than HII or its authorized representatives.

This warranty shall extend from the time of shipment for the duration published by HII for the product at the time of purchase ("Warranty Period"). Any defective product must be returned (at purchaser's expense) during the Warranty Period to HII factory or authorized service center for inspection. No product will be accepted by HII without a Return Materials Authorization, which may be obtained by contacting HII. In the event that the product is returned to HII or its authorized service center within the Warranty Period and HII determines to its satisfaction that the product is defective due to defects in materials or workmanship, HII, at its sole option, will either repair or replace the product without charge, except for return shipping to HII.

EXCEPT AS MAY BE OTHERWISE PROVIDED BY APPLICABLE LAW, THE FOREGOING WARRANTY IS IN LIEU OF ALL OTHER COVENANTS OR WARRANTIES, EITHER EXPRESSED OR IMPLIED, ORAL OR WRITTEN, INCLUDING, WITHOUT LIMITATION, ANY IMPLIED WARRANTIES OF MERCHANTABILITY OR FITNESS FOR A PARTICULAR PURPOSE, OR NON-INFRINGEMENT.

HII'S RESPONSIBILITY AND PURCHASER'S EXCLUSIVE REMEDY UNDER THIS WARRANTY IS LIMITED TO THE REPAIR OR REPLACEMENT OF THE DEFECTIVE PRODUCT WITH NEW OR REFURBISHED PARTS. IN NO EVENT SHALL HII BE LIABLE FOR INDIRECT, INCIDENTAL, OR CONSEQUENTIAL DAMAGES, AND, IN NO EVENT, SHALL ANY LIABILITY OF HII ARISING IN CONNECTION WITH ANY PRODUCT SOLD HEREUNDER (WHETHER SUCH LIABILITY ARISES FROM A CLAIM BASED ON CONTRACT, WARRANTY, TORT, OR OTHERWISE) EXCEED THE ACTUAL AMOUNT PAID TO HII FOR THE PRODUCT. THESE LIMITATIONS ON LIABILITY SHALL REMAIN IN FULL FORCE AND EFFECT EVEN WHEN HII MAY HAVE BEEN ADVISED OF THE POSSIBILITY OF SUCH INJURIES, LOSSES, OR DAMAGES. SOME STATES, PROVINCES, OR COUNTRIES DO NOT ALLOW THE EXCLUSION OR LIMITATIONS OF INCIDENTAL OR CONSEQUENTIAL DAMAGES, SO THE ABOVE LIMITATION OR EXCLUSION MAY NOT APPLY TO YOU.

All provisions of this Limited Warranty are separate and severable, which means that if any provision is held invalid and unenforceable, such determination shall not affect the validity of enforceability of the other provisions hereof. Use of any peripherals not provided by the manufacturer may result in damage not covered by this warranty. This includes but is not limited to: cables, power supplies, cradles, and docking stations. HII extends these warranties only to the first end-users of the products. These warranties are non-transferable.

The duration of the limited warranty for the IS4920 and IS4921 is two year(s).



# ***Patents***

For patent information, please refer to [www.honeywellaidc.com/patents](http://www.honeywellaidc.com/patents).

## A

Aiming ..... 16, 34  
Ambient Light ..... 16  
Ambient Temperature ..... 15  
Area Illumination ..... 4  
ASCII ..... 22, 23  
Assembly ..... 3

## B

Bar Code ..... 29, 30, 32  
Bracket ..... 3  
Bus ..... 16

## C

Cable ..... 15  
Camera Aperture ..... 4, 13  
CMOS sensor ..... 1, 16  
Connector ..... 4, 5, 10, 33, 37–41, 44, 45  
Contaminants ..... 12, 33, 49  
Contrast ..... 32  
Current ..... 34  
Customer Service ..... 49, 53, 54

## D

Depth of Field ..... 29, 30, 32  
Divergence Angle ..... 14, 29, 30

## E

Electrical  
  Current Draw ..... 36  
  DC voltages ..... 34  
  Max Ratings ..... 34  
Electrical Specification ..... 34, 46  
Electrostatic Discharge ..... 12, 34, 49  
EMC ..... 46, 47  
Enclosure ..... 12–14, 44, 45, 49

## F

Field of View ..... 13, 29, 30, 32  
FirstFlash® ..... 1, 4, 16, 27  
Flex Cable ..... See Cable

## G

Ground ..... 12, 37–41

## H

Humidity ..... 12, 33, 49

## I

Illumination ..... 4, 13, 14, 34, 37–41  
Imager ..... 4  
Imaging Engine ..... 1, 4  
Imaging Sensor ..... 16  
Input ..... 34, 37–41

## K

Keying ..... 4, 33  
Keying Location ..... 6–11

## L

Label ..... 5  
Light Levels ..... 34  
Light Source ..... 32  
Limited Warranty ..... 49

## M

Mega-pixel ..... 1  
Mode  
  serial ..... 22  
  Snapshot ..... 16, 34  
  Video ..... 16, 34  
Model ..... 1  
Mounting ..... 6–11

## O

Optical Clearance ..... 14  
ORC  
  Fonts ..... 1  
  MICR ..... 1  
  ORC-A ..... 1  
  ORC-B ..... 1  
Output ..... 37–41

## P

Part Number ..... 1  
PCLK ..... 16  
Pin ..... 37–41  
Pixel ..... 16, 37–41  
Plug ..... 32, 37–41  
Power ..... 15  
Power Supply ..... 15

---

## R

Receptacle .....	16, 44, 45
Regulatory Compliance .....	46, 47
Resolution .....	32
RMA .....	49

## S

Self-Tapping Screw .....	1, 4, 6–11
Serial Configuration .....	22
Serial Label .....	5
Service .....	49, 53, 54
Shock .....	33, 44, 45
Signals .....	15–28, 34, 37–41
Snapshot Mode .....	16, 34
SwiftDecoder™ .....	1

## T

Targeting .....	4, 37–41
Temperature .....	33

Thermal Temperature .....	15
Threaded Inserts .....	8
Timing .....	24
Torque .....	6–11
Trigger .....	37–41

## V

Video Mode .....	16, 34
Voltage .....	34, 37–41, 46, 47

## W

Warranty .....	49
Watt(s) .....	46
Weight .....	33
Window	
coatings .....	13
materials .....	13
specifications .....	13
transmission .....	13



# Customer Support

## **Technical Assistance**

If you need assistance installing or troubleshooting your device, please call your distributor or the nearest technical support office:

### **North America/Canada**

Telephone: (800) 782-4263

*E-mail: [hsmnasupport@honeywell.com](mailto:hsmnasupport@honeywell.com)*

### **Latin America**

Telephone: (803) 835-8000

Telephone: (800) 782-4263

*E-mail: [hsmlasupport@honeywell.com](mailto:hsmlasupport@honeywell.com)*

### **Brazil**

Telephone: +55 (11) 5185-8222

Fax: +55 (11) 5185-8225

*E-mail: [brsuporte@honeywell.com](mailto:brsuporte@honeywell.com)*

### **Mexico**

Telephone: 01-800-HONEYWELL (01-800-466-3993)

*E-mail: [soporte.hsm@honeywell.com](mailto:soporte.hsm@honeywell.com)*

### **Europe, Middle East, and Africa**

Telephone: +31 (0) 40 7999 393

Fax: +31 (0) 40 2425 672

*E-mail: [hsmeurosupport@honeywell.com](mailto:hsmeurosupport@honeywell.com)*

### **Hong Kong**

Telephone: +852-29536436

Fax: +852-2511-3557

*E-mail: [aptechsupport@honeywell.com](mailto:aptechsupport@honeywell.com)*

### **Singapore**

Telephone: +65-6842-7155

Fax: +65-6842-7166

*E-mail: [aptechsupport@honeywell.com](mailto:aptechsupport@honeywell.com)*

### **China**

Telephone: +86 800 828 2803

Fax: +86-512-6762-2560

*E-mail: [aptechsupport@honeywell.com](mailto:aptechsupport@honeywell.com)*

### **Japan**

Telephone: +81-3-3839-8511

Fax: +81-3-3839-8519

*E-mail: [aptechsupport@honeywell.com](mailto:aptechsupport@honeywell.com)*

## **Online Technical Assistance**

You can also access technical assistance online at [www.honeywellaidc.com](http://www.honeywellaidc.com).

---

## **Product Service and Repair**

Honeywell International Inc. provides service for all its products through service centers throughout the world. To obtain warranty or non-warranty service, contact the appropriate location below to obtain a Return Material Authorization number (RMA #) before returning the product.

### **North America**

Telephone: (800) 782-4263  
E-mail: [hsmnaservice@honeywell.com](mailto:hsmnaservice@honeywell.com)

### **Latin America**

Telephone: (803) 835-8000  
Telephone: (800) 782-4263  
Fax: (239) 263-9689  
E-mail: [laservice@honeywell.com](mailto:laservice@honeywell.com)

### **Brazil**

Telephone: +55 (11) 5185-8222  
Fax: +55 (11) 5185-8225  
E-mail: [brservice@honeywell.com](mailto:brservice@honeywell.com)

### **Mexico**

Telephone: 01-800-HONEYWELL (01-800-466-3993)  
Fax: +52 (55) 5531-3672  
E-mail: [mxservice@honeywell.com](mailto:mxservice@honeywell.com)

### **Europe, Middle East, and Africa**

Telephone: +31 (0) 40 2901 633  
Fax: +31 (0) 40 2901 631  
E-mail: [euroservice@honeywell.com](mailto:euroservice@honeywell.com)

### **Hong Kong**

Telephone: +852-29536436  
Fax: +852-2511-3557  
E-mail: [apservice@honeywell.com](mailto:apservice@honeywell.com)

### **Singapore**

Telephone: +65-6842-7155  
Fax: +65-6842-7166  
E-mail: [apservice@honeywell.com](mailto:apservice@honeywell.com)

### **China**

Telephone: +86 800 828 2803  
Fax: +86-512-6762-2560  
E-mail: [apservice@honeywell.com](mailto:apservice@honeywell.com)

### **Japan**

Telephone: +81-3-3839-8511  
Fax: +81-3-3839-8519  
E-mail: [apservice@honeywell.com](mailto:apservice@honeywell.com)

### **Online Product Service and Repair Assistance**

You can also access product service and repair assistance online at [www.honeywellaidc.com](http://www.honeywellaidc.com).

**Honeywell Scanning & Mobility**

9680 Old Bailes Road

Fort Mill, SC 29707

[www.honeywellaidc.com](http://www.honeywellaidc.com)



00-05325 Rev H  
November 2010